



## Product Information PI 31.2

### Disk-type tool with y-axis slide feet unit

Series      **0.5.453.4xx**  
                 **0.5.493.5xx**  
                 **0.5.693.1xx**  
                 **0.5.439.1xx**

2011-11-22

Attention

High pressure turret exceeding 50bar : For safety purpose, it is required to use high pressure tool holders which match specifications of turret.

雷特國際股份有限公司  
**SAUTER ASIA CO., LTD.**

408台中市南屯區環中路四段368號

No. 368, Sec. 4, Huangzhong Rd., Nantun District, Taichung, Taiwan

TEL: 886-4-23805836 FAX: 886-4-23805832 WEB: [www.sauter-asia.com](http://www.sauter-asia.com) E-mail: [info@sauter-asia.com](mailto:info@sauter-asia.com)

上海德雷精密機械有限公司  
**GP INTERNATIONAL CO., LTD**

上海市松江區新橋鎮民強路301號22棟廠房

Building 22, No.301, Minqiang Road, Xinqiao Town, Songjiang District Shanghai, China

TEL:+86-21-5764-9075 FAX:+86-21-5764-9076 WEB:[www.gpi-china.com](http://www.gpi-china.com) E-mail: [infocn@gpinternational.com.cn](mailto:infocn@gpinternational.com.cn)



## Index

<b>Description .....</b>	<b>5</b>
<b>Disk-type tool turret Series 0.5.453.4xx</b>	
Technical data.....	6
Dimension illustration.....	8
Dimension .....	9
<b>Disk-type tool turret Series 0.5.493.5xx</b>	
Technical data.....	10
Dimension illustration.....	12
Dimension .....	13
<b>Disk-type tool turret Series 0.5.693.1xx</b>	
Technical data.....	17
Dimension illustration.....	18
Dimension .....	19
<b>Disk-type tool turret Series 0.5.439.1xx</b>	
Technical data.....	20
Dimension illustration.....	21
Dimension .....	22
<b>Ordering Details .....</b>	<b>23</b>
<b>Assignment of control plans .....</b>	<b>24</b>
Wiring schematic .....	EP-937
.....	EP-1076
.....	EPB-1175
.....	EPB-1251
Hydraulic plan .....	HP-451
.....	HP-496
.....	HP-498
Function diagramm .....	SK-919
.....	SK-940
.....	SK-1307
.....	SK-1473
.....	SK-1487

### NOTES:

The information given in this product information is based on the details available at the time of printing. We explicitly reserve the right to make changes arising out of the continuous further development of the product.

## Description

### Configuration of principle

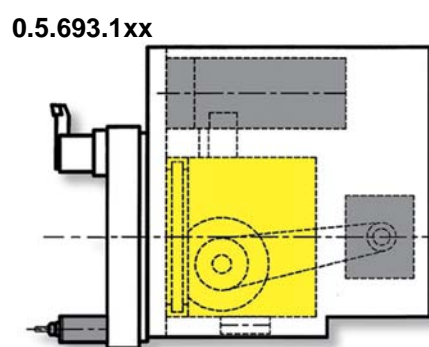
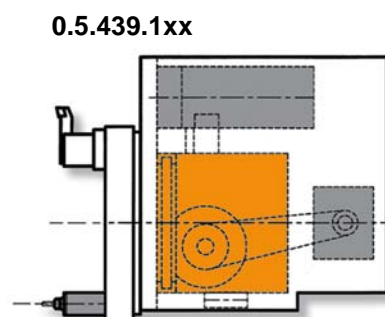
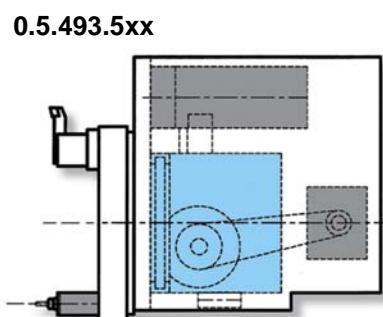
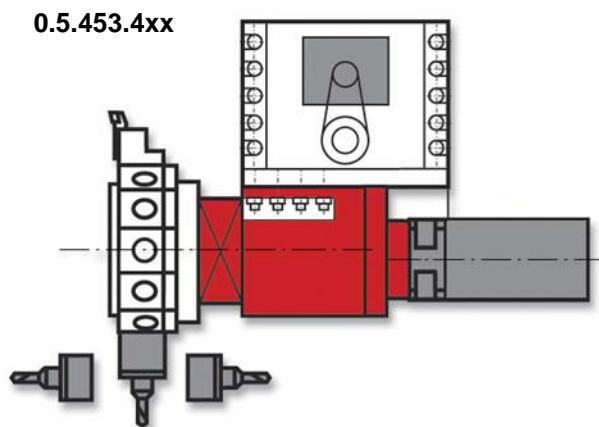

## Description

### SAUTER disk-type tool turret with y-axis-slide feed unit

SAUTER disk-type tool turret are available in different designs also featuring a y-axis slide feed unit adjustable with a CNC machine. This allows for off centre drilling with powered tools as well as tapping and CNC plane milling..

For **forward and reverse** machine, the turret system

- **0.5.453.4xx** with servo electrical turret drive and hydraulic latching is available.

For **forward machining**, the turret systems

- **0.5.493.5xx** with electromechanical design
- **0.5.693.1xx** with rein hydraulic function und
- **0.5.439.1xx** servo-electrical tool turret drive und hydraulic latching.

The slide feed units of the turrets 0.5.453.4xx and 0.5.693.1xx feature permanently lubricated, pre-stressed roller guides. They are powered by a servomotor with toothed belt and ball screw spindle.

The slide feed unit position is detected by the motor sensor.

The slide feed unit guides of the turret system 0.5.493.5xx are constructed flat .

They are also powered by a servomotor, toothed belt and ball screw spindle.

The exact slide feed unit position is detected by a separated linear measurement system.

The slide feed units are also positioned by the motor in case of rotating operations so that any additional clamping or locking mechanisms are not required.

## Technical Data 0.5.453.4xx

<b>Series</b>	
<b>Disk-type tool turret 0.5.453.4xx</b>	
<b>Number of switching positions</b>	
<b>Loads</b>	
Adm. tangential moment	kNm
<b>Tooling</b>	
Adm. mass moment of inertia	kgm <sup>2</sup>
Adm. mass	kg
Adm. unbalanced mass	Nm
<b>Switching times</b>	
Rotation time per 30° -sub step	s
Rotation time per 30° -additional sub step	s
Turret unlocked or locked	s
<b>Cooling lubricant</b>	
Adm. operating pressure	bar
<b>Tool drive</b>	
Drive motor <sup>1)</sup> Model Siemens Servomotor	1FT6-..
Drive motor <sup>1)</sup> Model Fanuc Servomotor	α..
Drive motor <sup>1)</sup> Model Fanuc Spindlemotor	α..
Gear ratio	i
Max. torque 40% ED	Nm
Max. rpm	min <sup>-1</sup>
<b>Y-axis-slide feed unit</b>	
Drive motor <sup>1)</sup> Model Siemens/Fanuc with breake	
Gear ratio	i
Incline of ball screw spindle	mm
Adm. rapid feed speed	m/min
Working stroke ΔY	mm
Adm. feed force	kN
Linear measurement system	
Possible positioning precision	μm
<b>Mass</b>	
Turret, complete, without tool holder, approx.	kg

1) Not part of SAUTER-standard scope of delivery.

All data are identical for right and left constructions. See product information PI 21.3 for additional information.

Size					
12		16		20	
12		12		12	
0,8		1,8		3,6	
0,8		1,8		3,2	
25		35		60	
12		25		40	
0,12		0,14		0,16	
0,05		0,05		0,06	
0,10		0,10		0,12	
5 ... 25		5 ... 25		5 ... 25	
..064..AK..		084..AK..		086..AH..	
8/4000 is		12/4000 is		22/4000 is	
1,5		2		3	
1,0		1,0		1,0	
14	15	28	25	40	40
6000		5000		4000	
1FT6-061..AH..	Alpha 2/3000	1FT6-061..AH..	Alpha 2/3000	1FT6-064..AH..	Alpha M8/3000 i(s)
2,0		2,0		2,0	
5		5		5	
10	7,5	10	7,5	10	9
± 40		± 40		± 55	
1,6		2		3,2	
Transmitter		Transmitter		Transmitter	
10		10		10	
ca. 200		ca. 300		ca. 600	

Dimension illustration Series 0.5.453.4xx

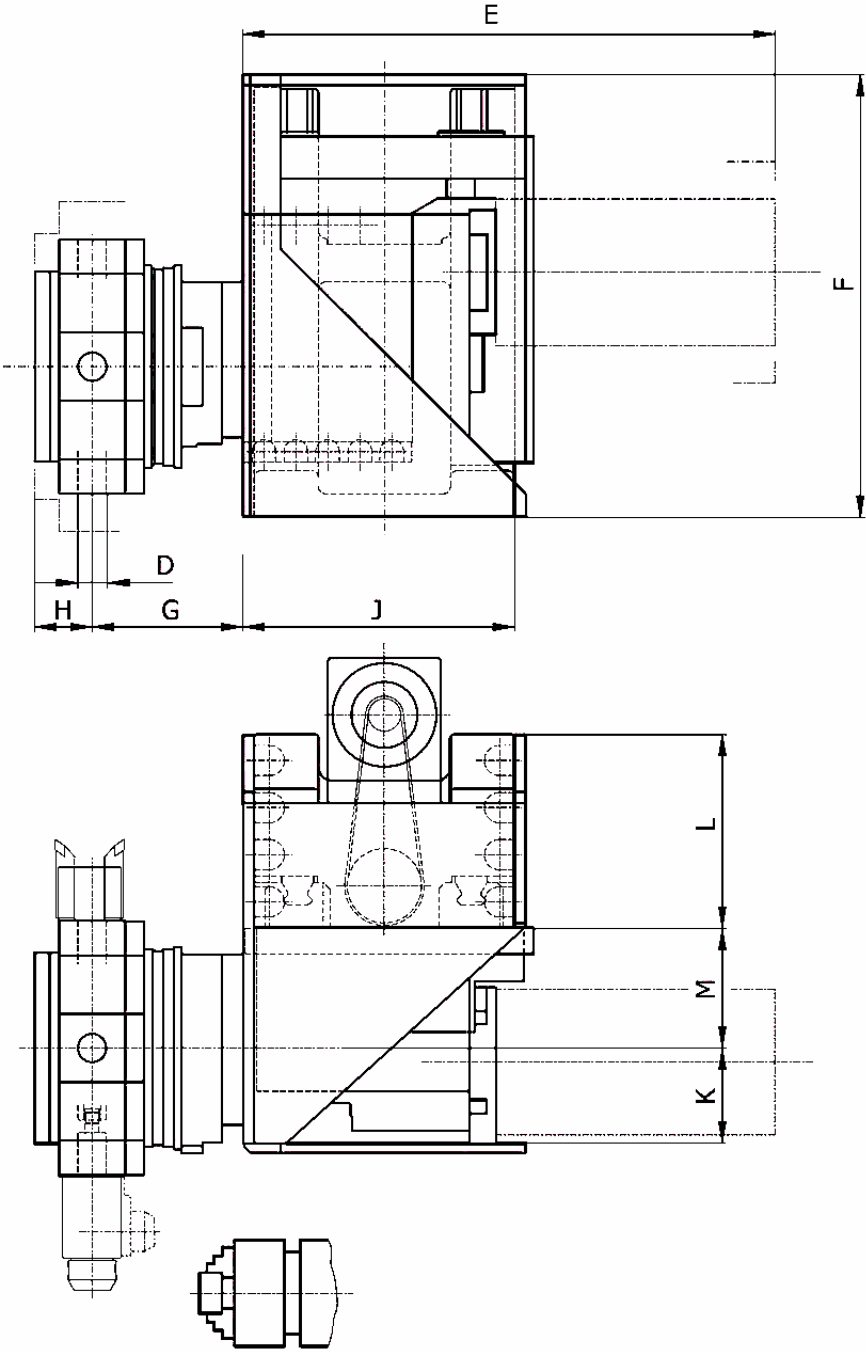



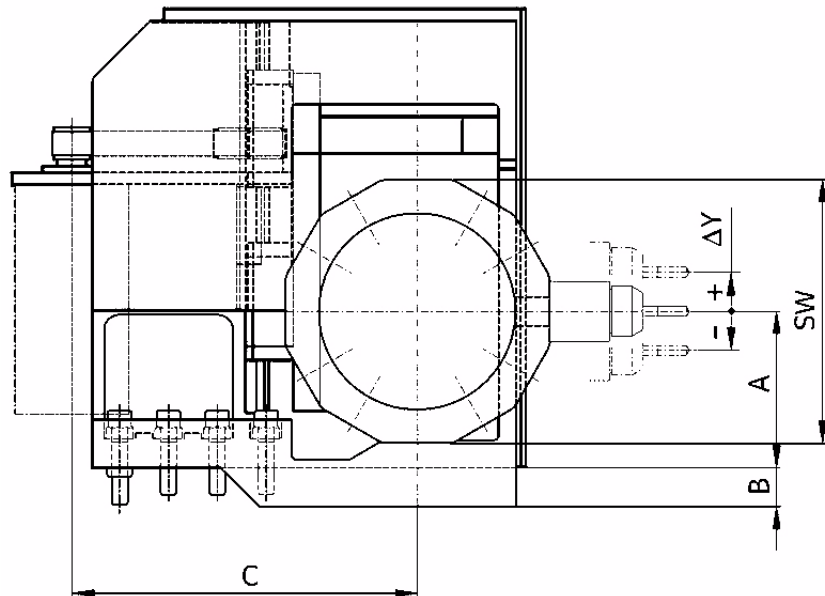

## Dimension

Series		Size		
Disk-type tool turret 0.5.453.4xx		12	16	20
Dimension	SW	220	270	320
	A	130	160	240
	B	40	40	80
	C <sup>1)</sup>	266	354	348
	Ø D	25	30	40
	E <sup>1)</sup>	597	564	642
	F	470	470	644
	G	124	160	200
	H	62	61	63
	J	288	288	412
	K	81	101	127
	L	206	206	276
	M	118	128	171

Dimensions in mm

1) Depends on motor  
All dimensions are identical for right and left constructions.

## Technical Data 0.5.493.5xx

<b>Series</b>	
Disk-type tool turret 0.5.493.5xx	
<b>Number of switching positions</b>	
<b>Loads</b>	
Adm. tangential moment	kNm
<b>Tooling</b>	
Adm. mass moment of inertia	kgm <sup>2</sup>
Adm. Mass	kg
Adm. unbalanced mass	Nm
<b>Switching times</b>	
cycle time per 30° -sub step	s
Rotation time per 30° -additional sub step	s
Adm. switching frequency	1/min
<b>Cooling lubricant</b>	
Adm. operating pressure	<ul style="list-style-type: none"> <li>• standard</li> <li>• with medium pressure valve</li> </ul>
	bar bar
<b>Tool drive</b>	
Drive motor <sup>1)</sup> Model Siemens/Fanuc	
Gear ratio	
max. torque 40% DC (duty cycle)	Nm
max. rpm	min <sup>-1</sup>
<b>Y-axis-slide feed unit</b>	
Drive motor <sup>1)</sup> Model Siemens/Fanuc with breake	
Gear ratio	
Incline of ball screw spindle	mm
Adm. rapid feed speed	m/min
Adm. feed stroke	mm
Working stroke $\Delta Y$	mm
Adm. feed force	kN
Linear measurement system, company Heidenhain	
Possible positioning precision	$\mu\text{m}$
<b>Mass</b>	
Turret, complete, without tool holder, approx.	kg

1) Not part of SAUER standard scope of delivery

2) With external deactivation

All data are identical for right and left construction. See brochure R54 for additional information.

Size				
10	25		32	
12	12		12	
0,3	6		12	
0,20	7		28	
100	100		160	
14	135		250	
0,45	0,89		1,35	
0,16	0,34		0,54	
16	6,3		3,3	
7/14 <sup>2)</sup> 5 ... 25	7/14 <sup>2)</sup> 5 ... 25		7/14 <sup>2)</sup> 5 ... 25	
$\alpha$ 4/5000 is	1FT6-102 ...	$\alpha$ 30/3000	1PH7107-2NF 22	$\alpha$ 12
1	1,938	1,348	1,625	1,238
8	63	63	130	110
6000	2300	2250	3000	3000
$\alpha$ 2/5000 is	1FT6-084 ...	$\alpha$ 6	1FT6-- 105	$\alpha$ 40
1	2		2	
5	10		10	
10	10		10	
$\pm$ 25	$\pm$ 58		$\pm$ 80	
$\pm$ 25	$\pm$ 65		$\pm$ 80	
???	4,5		8	
—	LS 406		LS 406	
10	10		10	
—	ca. 650		ca. 1050	

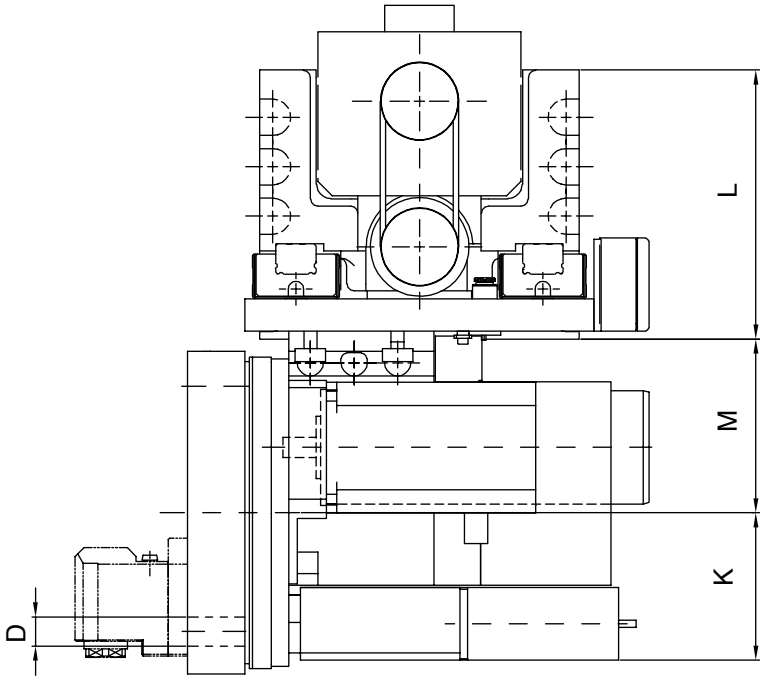
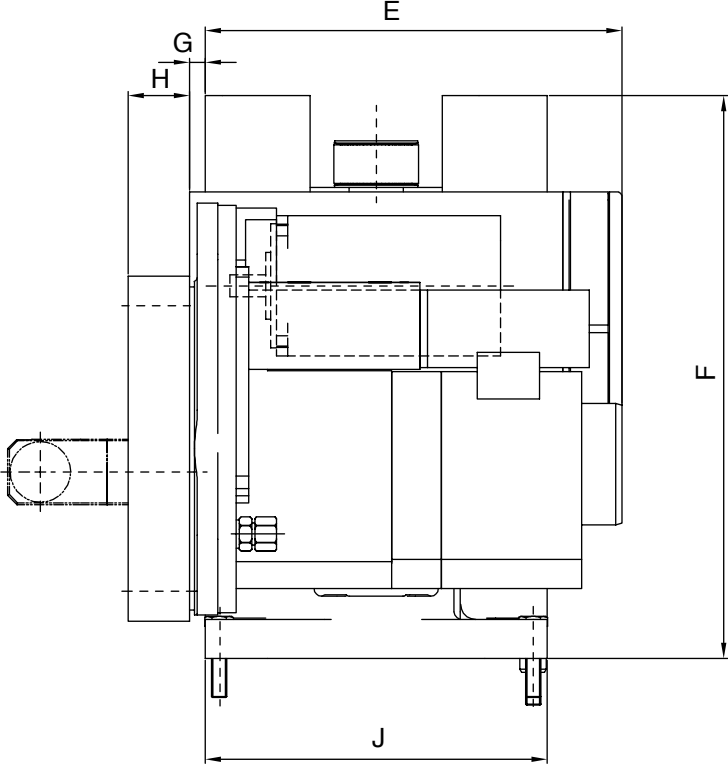

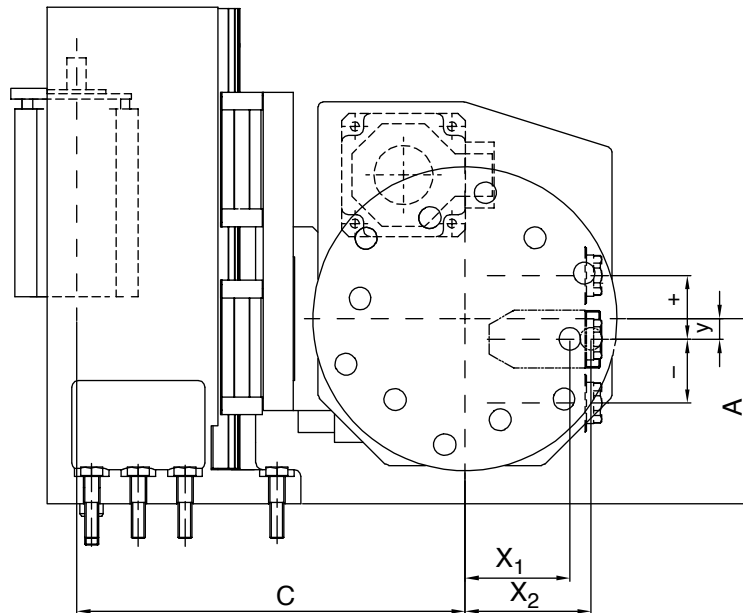

## Dimension

Series		Size
Disk-type tool turret 0.5.493.5xx		10
Dimension	X <sub>1</sub> / X <sub>2</sub>	76,5 / 93
	Y	15
	A	135
	C <sup>1)</sup>	283
	D	16
	E	268
	F	362
	G	10
	H	39,5
	J	220
	K	101,5
	L	18,5
	M	119,5

Dimension in mm

- 1) Depends on motor.  
All dimensions are identical for right and left constructions.

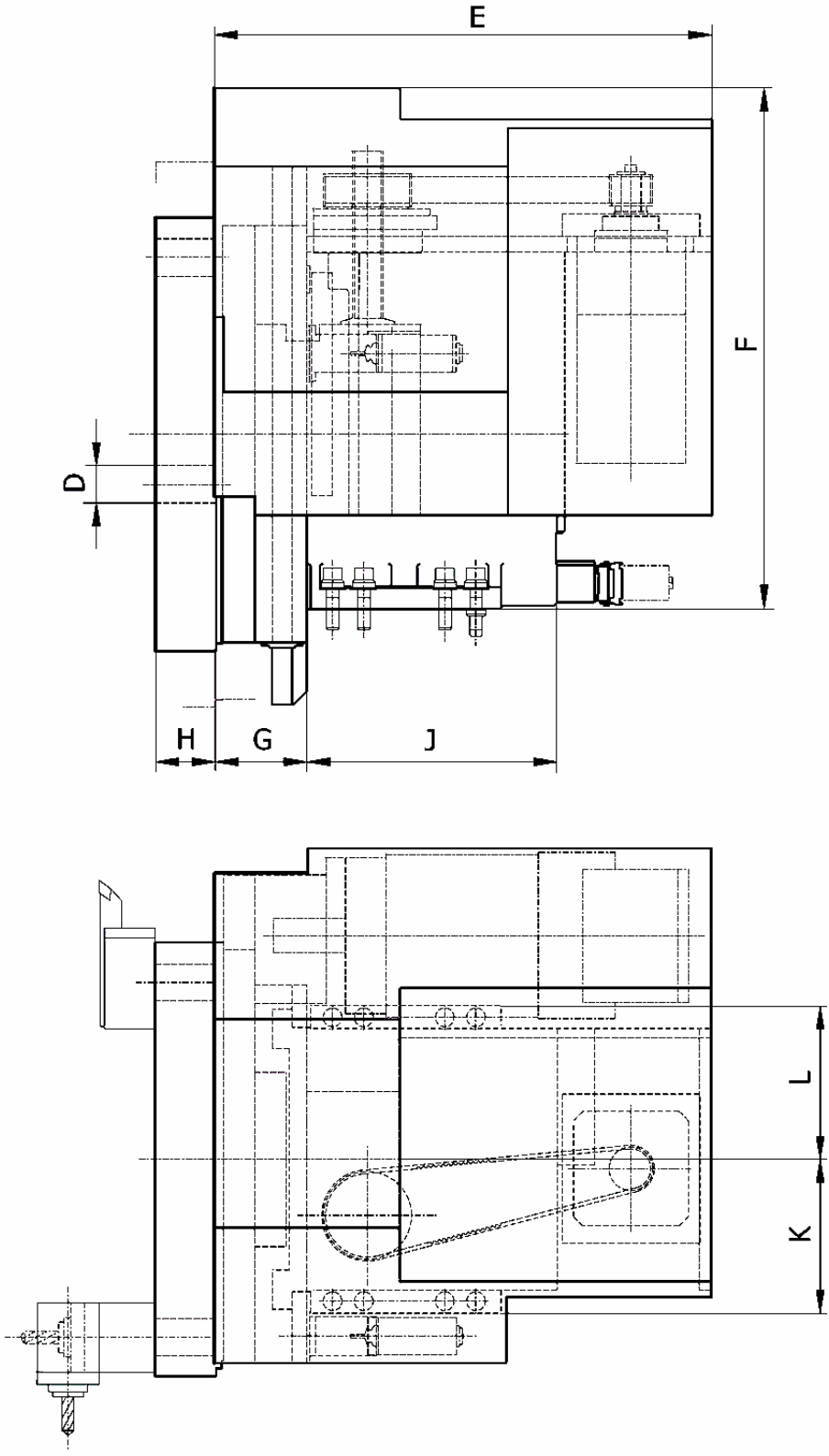

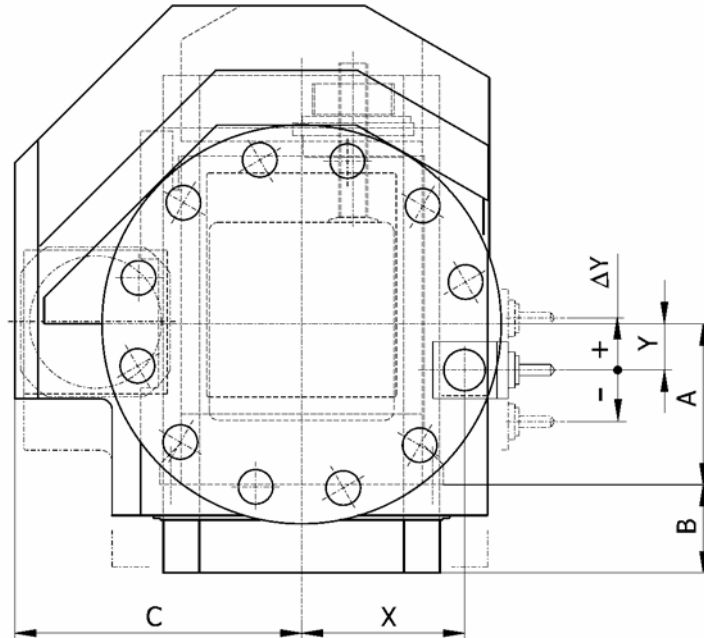

### Dimensio

Series		Baugröße	
Disk-type tool turret 0.5.493.5xx		25	32
Dimension	X	224,33	283,95
	Y	70	80
	A	230	280
	B	102	154
	C <sup>1)</sup>	389	460
	D	50	60
	E	655	795
	F	711	836
	G	122	146
	H	82	98
	J	329	401
	K	176	247
	L	211	247

Dimension in mm

- 1) Depends on motor.  
All dimensions are identical for right and left constructions.





<b>Seires</b>		<b>Size</b>
<b>Disk-type tool turret 0.5.693.1xx</b>		<b>20</b>
<b>Number of switching positions</b>		12
<b>Loads</b>		
Adm. tangential moment	kNm	3,2
<b>Tooling</b>		
Adm. mass moment of inertia	kgm <sup>2</sup>	5
Adm. Mass)	kg	60
Adm. unbalanced mass	Nm	63
<b>Switching times</b>		
cycle time per 30° -sub step	s	0,24
Rotation time per 30° -additional sub step	s	0,15
Adm. switching frequency	s	0,20
<b>Cooling lubricant</b>		
Adm. operating pressure	<ul style="list-style-type: none"> <li>• Standard</li> <li>• with medium pressure valve</li> </ul>	bar bar 7/14 <sup>1)</sup> 5 .. 25
<b>Tool drive</b>		
Drive motor <sup>2)</sup> Model Siemens		1FT6-086..AH..
Gear ratio		1,0
max. torque 40% DC (duty cycle)	Nm	32
max. rpm	min <sup>-1</sup>	3000
<b>Y-axis-slide feed unit</b>		
Drive motor <sup>2)</sup> Model Siemens/Fanuc with break		1FT6-064..AH..
Gear ratio		2
Incline of ball screw spindle	mm	5
Adm. rapid feed speed	m/min	10
Working stroke	mm	± 55
Adm. feed force	kN	3,2
Linear measurement system, company Heidenhain		Transmitter
Possible positioning precision	μm	10
<b>Mass</b>		
Turret complete, without tool holder	kg	ca. 400

1) With external deactivation

2) Not part of SAUER standard scope of delivery

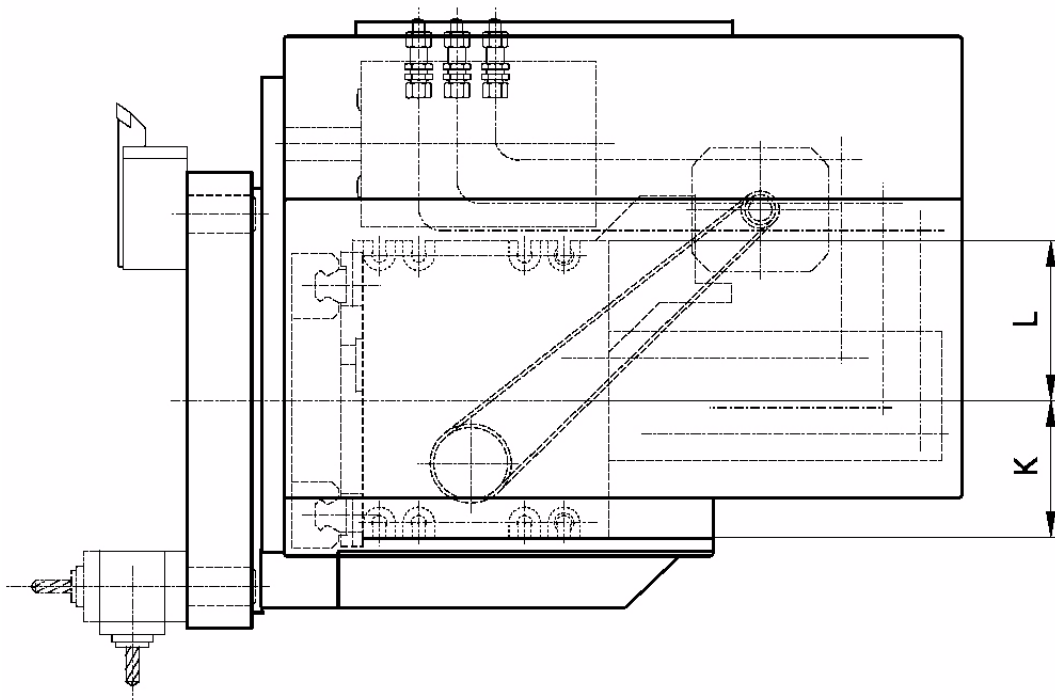
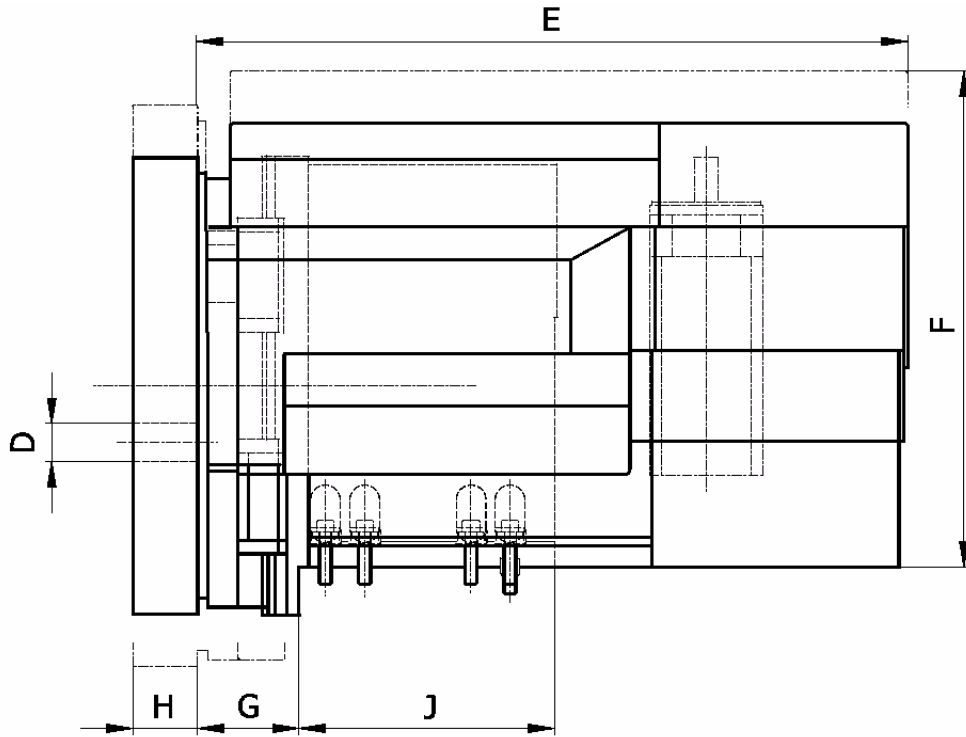

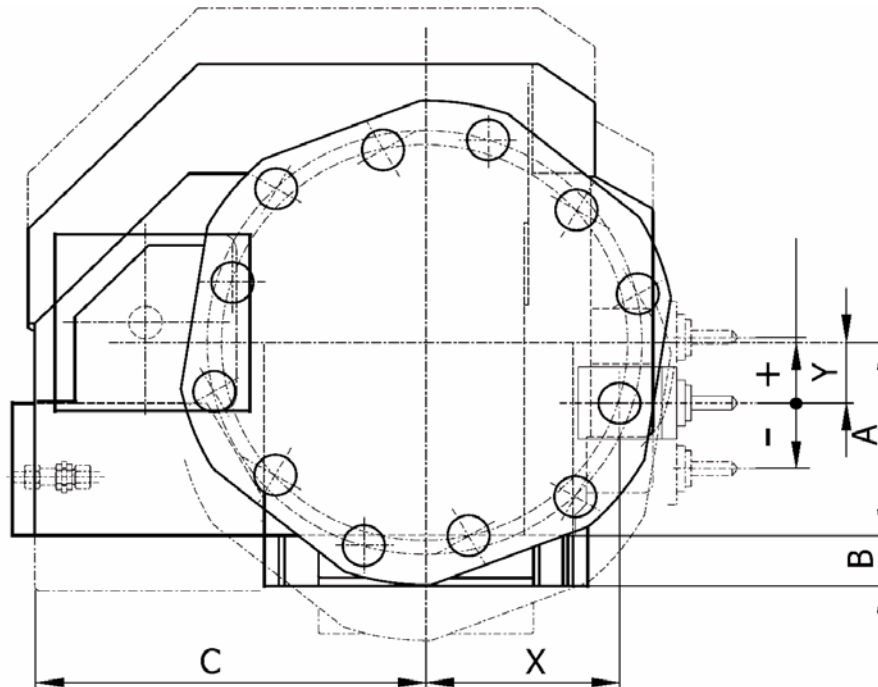

### Dimension

Seires		Size
Disk-type tool turret 0.5.693.1xx		20
Dimension	X	185,54
	Y	60
	A	190
	B	50
	C <sup>1)</sup>	435
	D	40
	E	723
	F	338
	G	103
	H	66
	J	260
	K	143
L	167	

Dimension in mm

1) Depends on motor

<b>Series</b>		<b>Size</b>
Disk-type tool turret 0.5.439.1xx		20
<b>Number of switching positions</b>		12
<b>Loads</b>		
Adm. tangential moment	kNm	3,6
<b>Tooling</b>		
Adm. mass moment of inertia	kgm <sup>2</sup>	5
Adm. Mass	kg	70
Adm. unbalanced mass	Nm	63
<b>Switching times</b>		
cycle time per 30° -sub step	s	0,15
Rotation time per 30° -additional sub step	s	0,09
Revolver	s	0,13
<b>Cooling lubricant</b>		
Adm. operating pressure • Standard	bar	7/14 <sup>1)</sup>
<b>Tool drive</b>		
Drive motor <sup>2)</sup> Model Siemens / Fanuc		1FT6-086..AH..
Gear ratio		1,0
max. torque 40% DC (duty cycle)	Nm	32
max. rpm	min <sup>-1</sup>	3000
<b>-axis-slide feed unit</b>		
Drive motor <sup>2)</sup> Model Siemens/Fanuc with breake		1FT6-064..AH..
Gear ratio		2
Incline of ball screw spindle	mm	5
Adm. rapid feed speed	m/min	10
Working stroke ΔY	mm	± 55
zul. Vorschubkraft	kN	3,2
Linear measurement system, company Heidenhain		Motorgeber
Possible positioning precision	μm	10
<b>Mass</b>		
Turret, complete, without tool holder	kg	ca. 400

1) With external deactivation

2) Not part of SAUER standard scope of delivery

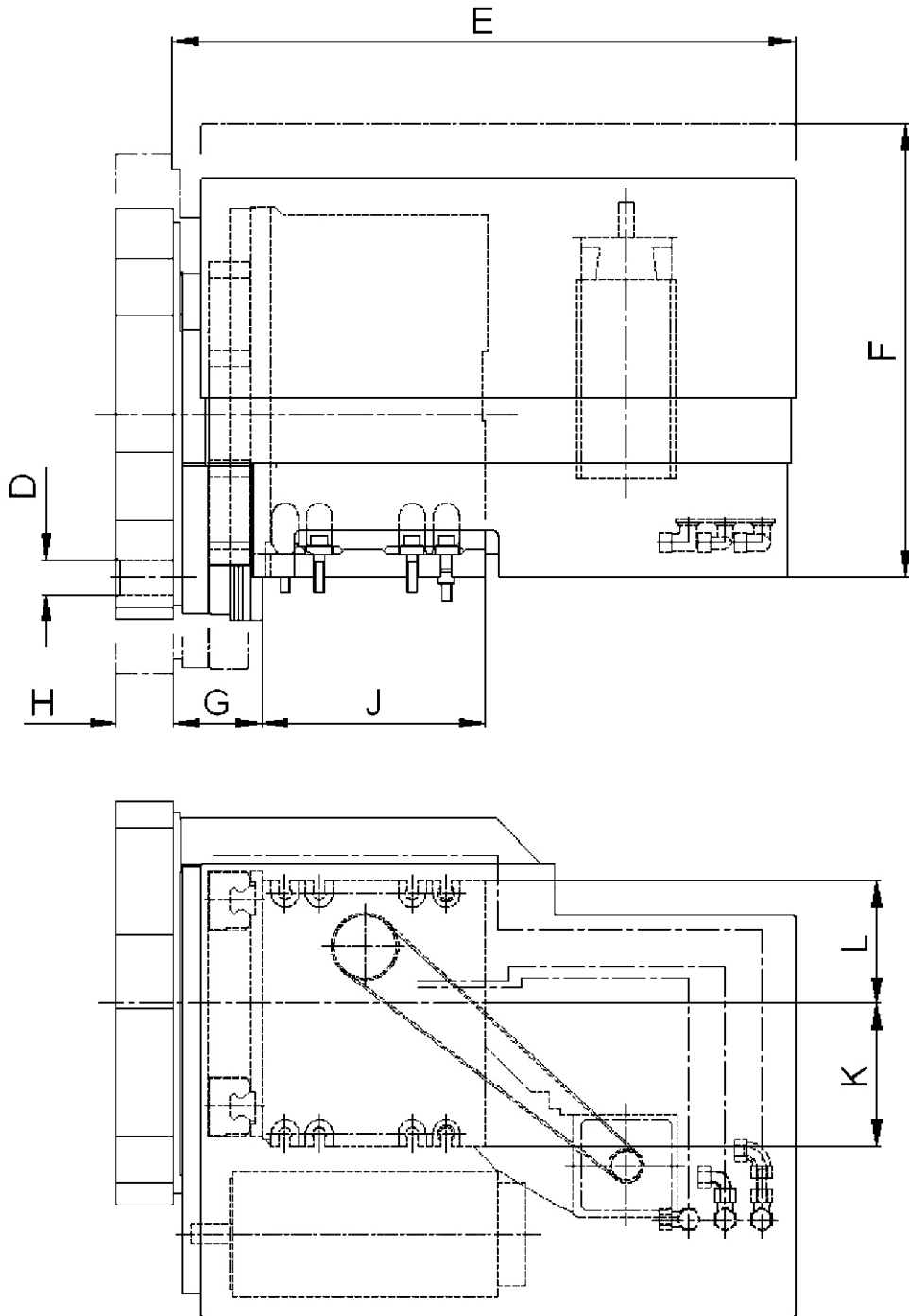

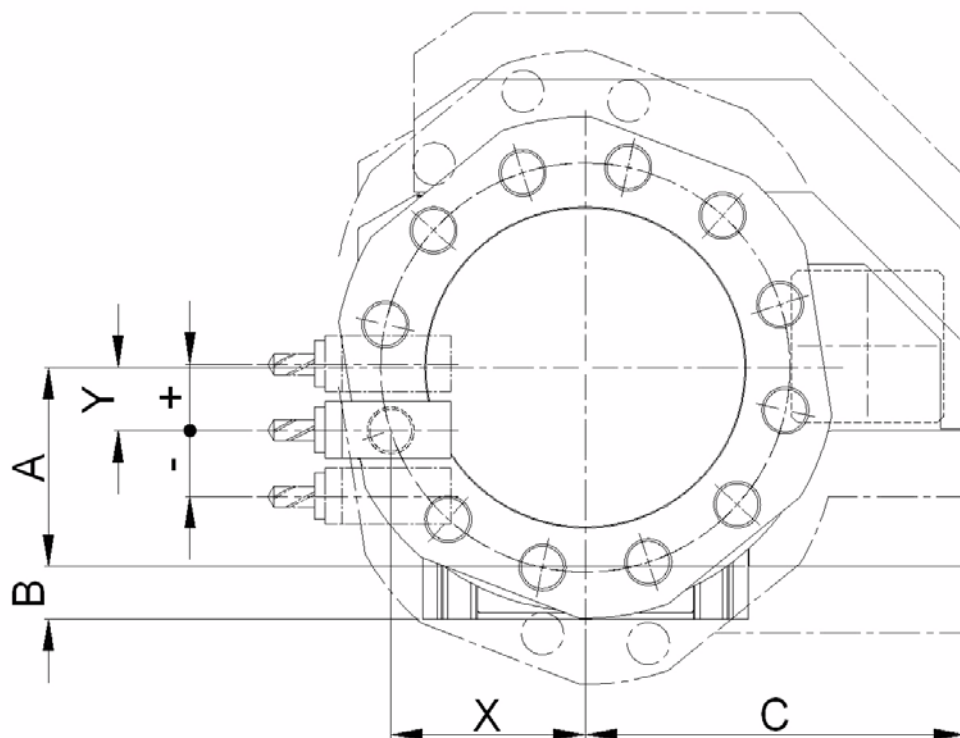

### Dimensionen

Series		Size
Disk-type tool turret 0.5.439.1xx		20
Dimension	X	185,54
	Y	60
	A	190
	B	50
	C <sup>1)</sup>	435
	D	40
	E	724
	F	528
	G	103
	H	66
	J	260
	K	143
L	167	

Dimension in mm

1) Depends on motor

## Ordering details



++49 (0) 7123-926-190



++49 (0) 123-926-0



info@sauter-feinmechanik.com



Sauter Feinmechanik GmbH  
Postfach 1551  
D-72545 Metzingen  
Germany

Firma: \_\_\_\_\_  
 Straße: \_\_\_\_\_  
 PLZ, Ort: \_\_\_\_\_  
 Name: \_\_\_\_\_  
 Tel.: \_\_\_\_\_  
 Fax: \_\_\_\_\_  
 E-Mail: \_\_\_\_\_

<b>SAUTER-Disk-type tool turret Y-axis slide feed unit</b>		
<b>Ordering details</b>	<b>Alternate configurations</b>	<b>Your selection</b>
<b>Turret-Type</b>	0.5.453.412 - Rechts / Links 416 - Rechts / Links 420 - Rechts / Links	
	0.5.493.525 - Rechts / Links 532 - Rechts / Links	
	0.5.693.120 - Rechts / - 0.5.439.120 - - / Links	
<b>Driving motors</b>	Fabrikat Siemens / Fanuc	
<b>Cooling lubricant</b>	Max. Betriebsdruck 7/14 bar 25 bar	
<b>Special requirements:</b>		
<b>Quantity:</b>		

---

**Assignment of control plans**

Turret-type	0.5.453.4xx	0.5.493.5xx	0.5.693.1xx	0.5.439.1xx
Wiring schematic Standard design	EPB - 1175	EP - 937	EP - 1076	EPB - 1251
Hydraulic plan	HP - 496	-	HP - 451	HP - 498
Function diagram	SK - 1487	SK - 919 SK - 940	SK - 940 SK - 1307	SK - 940 SK - 1473



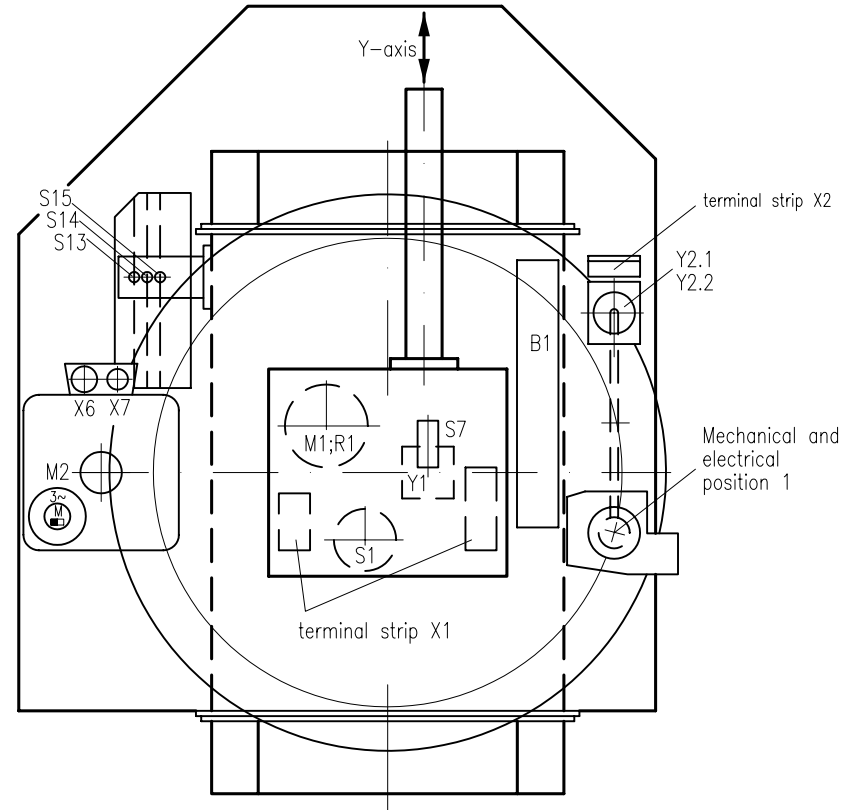
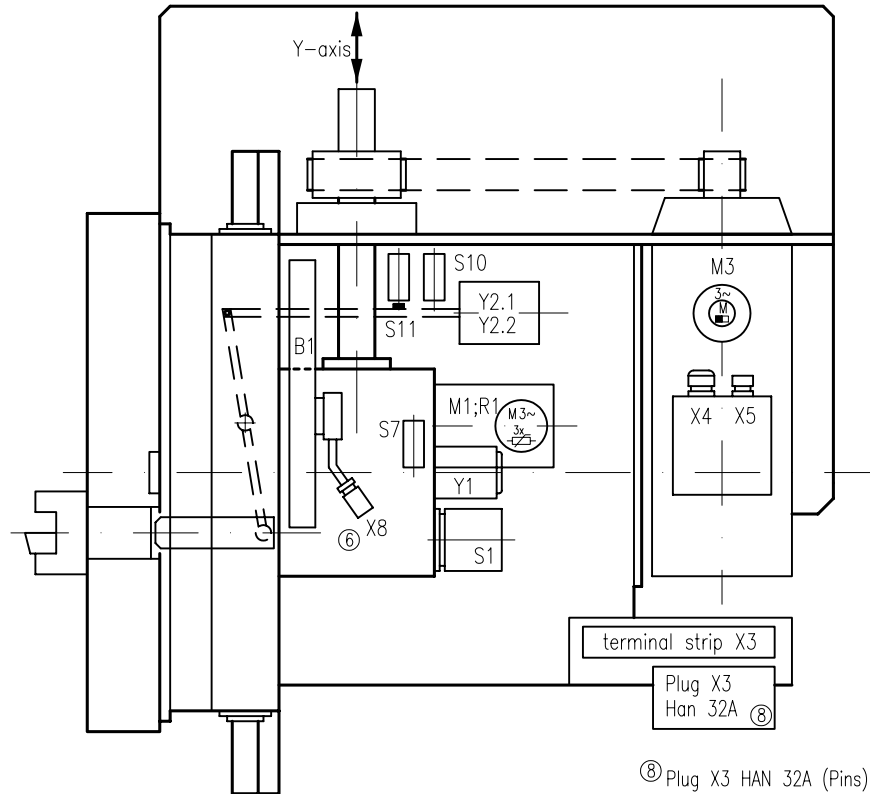

⑧ Plug X3 HAN 32A (Pins)

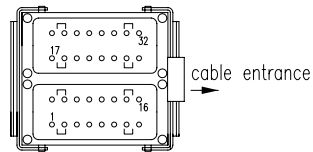

⑥ Optional (Adapter cable)

⑧ Optional



Designation	Element/Function	Line	Terminal strip X1	Cable from X1 to X3 12x0,75qmm	Cable from X1 to X3 12x0,34qmm	Cable from X3 to X3 6x0,5qmm	Terminal strip X2	Cable from X2 to X3 12x0,75qmm	Terminal strip X3	⑧ Plug X3 Han 32A	AC-servo motor terminal strip X4	Plug, signal line X5	AC-servo motor terminal strip X6	Plug, signal line X7	Plug X8	Type	Supplier
S1	Angular encoder	brown (+)	12 (+)		brown (+)				12 (+)	12						BRGB2-W <sub>0</sub> B <sub>12</sub> <sup>08</sup> -EP-P- $\frac{1}{R}$ -K BRGD0-WCD16-EP-P- $\frac{1}{R}$ -K	Balluff
		blue (-)	11 (-)		blue (-)				11 (-)	11							
		1.Bit white	1						1	1							
		2.Bit yellow	2						2	2							
		3.Bit green	3			green			3	3							
		4.Bit lilac	4			lilac			4	4							
		⑤ 5.Bit grey	5			grey			5	5							
		Strobe black	6			black			6	6							
		Parity pinc	7			pinc			7	7							
		screen	13			transparent			13	13							
S7	Proximity-Detector control pre-indexion	brown (+)	12 (+)													BES 516-324-E0-C-01	Balluff
		blue (-)	11 (-)														
		black	8		red				8	8							
S10	Proximity-Detector control Tool drive engaged	brown (+)					12 (+)	9	12 (+)	16						BES 516-324-E0-C-01	Balluff
		blue (-)					11 (-)	10	11 (-)	20							
		black					29	7	29	9							
S11	Proximity-Detector control Tool drive disengaged	brown (+)					12 (+)		12 (+)							BES 516-324-E0-C-01	Balluff
		blue (-)					11 (-)		11 (-)								
		black					30	8	30	10							
S13	Proximity detector in series Reference point	C 1				weiss			12 (+)	22						⑦	Balluff
		No 2				schwarz				33	21						
S14	Proximity detector in series End limitation y-axis above	C 1														BNS 113-B03-R12-61-A-12-03	Balluff
		No 2				blau				34	23						
S15	Proximity detector in series End limitation y-axis below	C 1															
		No 2				braun				35	24						
Y1	Solenoid Pre-indexing	brown (+)	② 16 (+)	6					16 (+)	14						24V DC; 2,8A; 40% ED	Schultz
		blue (-)	17 (-)	7					17 (-)	15							
Y2.1 Y2.2	Solenoid tool-drive	engaged						23 (+)	1	23 (+)	17					GTUW 050 T43 A2 24V DC; 21,2W	Schultz
		disengaged						24 (-)	2	24 (-)	18						
								24 (-)		24 (-)							
								25 (+)	3	25 (+)	19						
R1	Posistor-heat detector	blue	14	4					14	25						PTC-Thermistor nach DIN 44081 U <sub>le</sub> 4V DC	SAUTER
		blue	15	5					15	26							
M1	3-Phase A.C. Motor (release-indexing-locking)	U1	1						U1	27							SAUTER
		V1	2						V1	28							
		W1	3						W1	29							
		U2															
		V2															
		W2															
M2	Motor for tool drive AC-servomotor											U1 V1 W1	Order.Ref.-No 6FC9348-7AD		according to order	Siemens	
M3	Motor for Y-axis AC-servomotor											U1 V1 W1	Order.Ref.-No 6FC9348-7AD		according to order	Siemens	
B1	Length measuring system													⑥	LS 406/486 or LC 481/483 (absolute)	Heidenhain	

Technical Data of: S1 S7;S10;S11

Operating voltage: 15 – 30 V DC 10 – 24 V DC  $\hat{r}20\%$

Max. residual ripple: 10% 10%

Max. load current: 50mA (⑤ 25mA) 200mA

Nom. sensing distance: 1mm

Temperature range: 0ø bis +60øC -20ø bis + 65øC

Function: - n.o. (make) function

Type: pnp logic

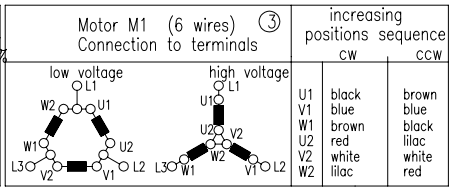

increasing positions sequence  
cw ccw

① for this, protective motor switch (thermistor) is required. Without thermistor motor protector no guarantee in case of motor failure.

② Diode 1N4006 (mounted to terminals). ⑦ Not required with LC 481

⑤ for 16 positions only. ⑥ Optional (Adapter cable) ⑧ Optional (Plug X3)

Edition 07.11.05 AI	<b>SAUTER</b> <i>Feinmechanik GmbH</i> <b>D-7430 Metzingen</b> Germany		Datum: 27.03.92	gez.: AI	gepr.:
------------------------	--	--	--------------------	-------------	--------



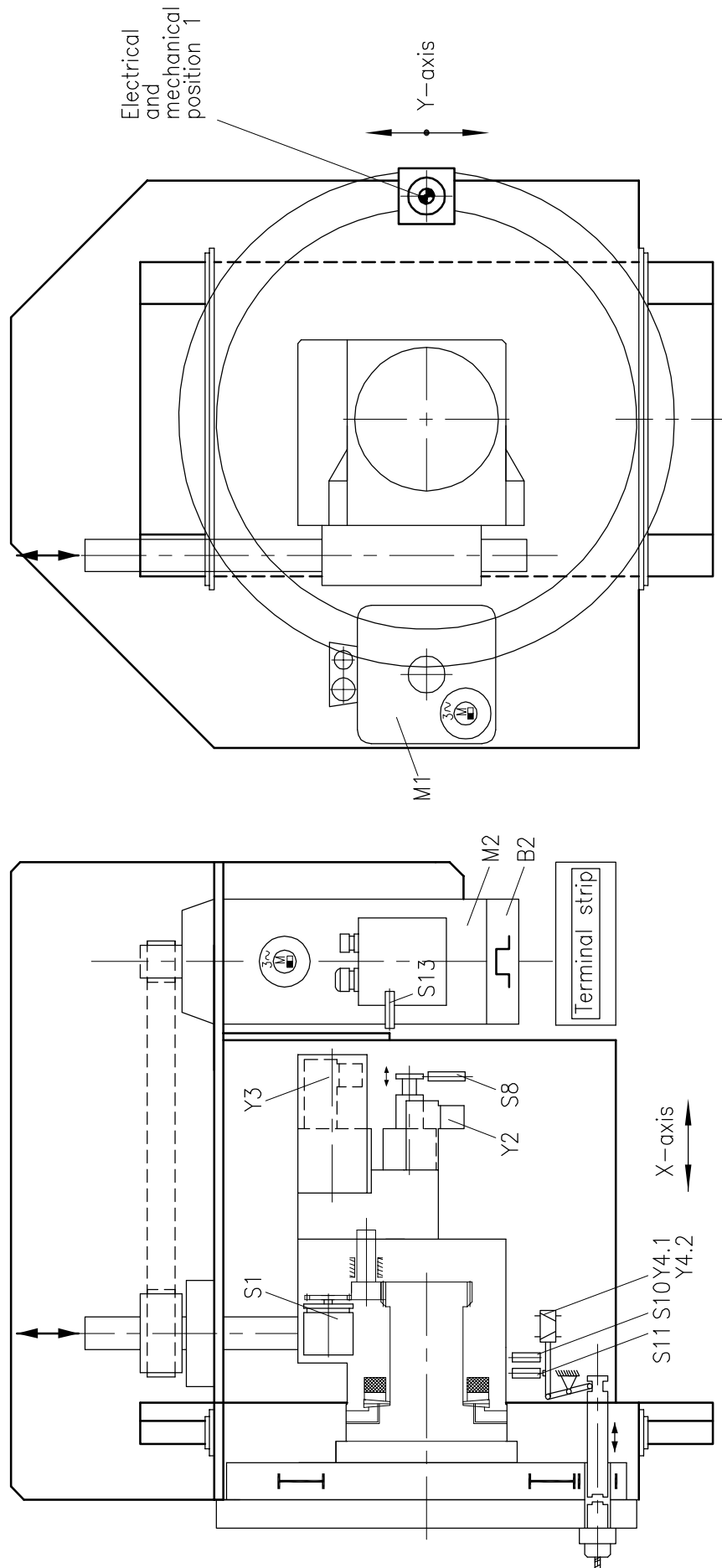



Designation	Element/function	Line from element	Terminals X1	④		Type	Manu- factura
				14x0,34 qmm	8x0,75 qmm		
S1	Angular position encoder	brown (+)	12	brown		BRGD2-W <sup>08</sup> <sub>D</sub> <sup>12</sup> -1 <sup>16</sup> -EP-P <sup>1</sup> <sub>R</sub> -K01	Balluff
		blue (-)	11	blue			
		1.Bit white	1	white			
		2.Bit yellow	2	yellow			
		3.Bit green	3	green			
		4.Bit violet	4	violet			
		③ 5.Bit grey	5	grey			
		Strobe black	6	black			
Parity pink	7	pink					
		transparent	13				
S8	Proximity switch "Turret in position"	brown (+)	12			BES 516-324-E0-C-01	Balluff
		blue (-)	11				
		black	10	red			
S10	Proximity switch control Tool drive engaged	brown (+)	12			BES 516-324-E0-C-01	Balluff
		blue (-)	11				
		black	29	red-blue			
S11	Proximity switch control Tool drive disengaged	brown (+)	12			BES 516-324-E0-C-01	Balluff
		blue (-)	11				
		black	30	grey-pink			
S13	Proximity switch Reference point Y-axis	brown (+)	12			BES 516-324-E0-C-01	Balluff
		blue (-)	11				
		black	33	white-green			
Y2	3/2 way valve "Start-Stop"	1 brown (+)	14		1	WKED 08130-04X-G24 24VDC; 1,04A	Hydac
		2 blue (-)	15		2		
Y3	4/2 way valve "Turret-sense of rotation"	1 brown (+)	16		3	WKEY 08140-04X-G24 24VDC; 1,04A	Hydac
		blue (-)	15				
Y4.1	Solenoid tool-drive engaged	brown (+)	23 (+)		4	GTUW 050 T43 D04 24VDC; 21,2W	Schultz
		blue (-)	24 (-)		5		
Y4.2	disengaged	brown (+)	24 (-)				
		blue (-)	25 (+)		6		
M1	Driving motor – Tool drive AC-servomotor					according to order	
B2	Incremental pulse coder					according to order	
M2	Driving motor – Y-axis AC-servomotor					according to order	
					green-yellow		

- ① Suppressor circuit (Z-diode) in the angle connector  
 ② Diode 1N4006 (mounted to terminals)  
 ③ Only for 16/24 positions  
 ④ Optional

Operating data of:	S1	S8, S10, S11, S13
Operating voltage:	15–30V DC	10–24V DC ±20%
Max. residual ripple:	10%	10%
Max. load current:	25mA	200mA
Nom. sensing distance:	–	1mm
Temperature range:	0° to + 60°C	–20° to + 65°C
Function:	–	n.o. (make) function
Type:	pnp-logik	pnp-logik





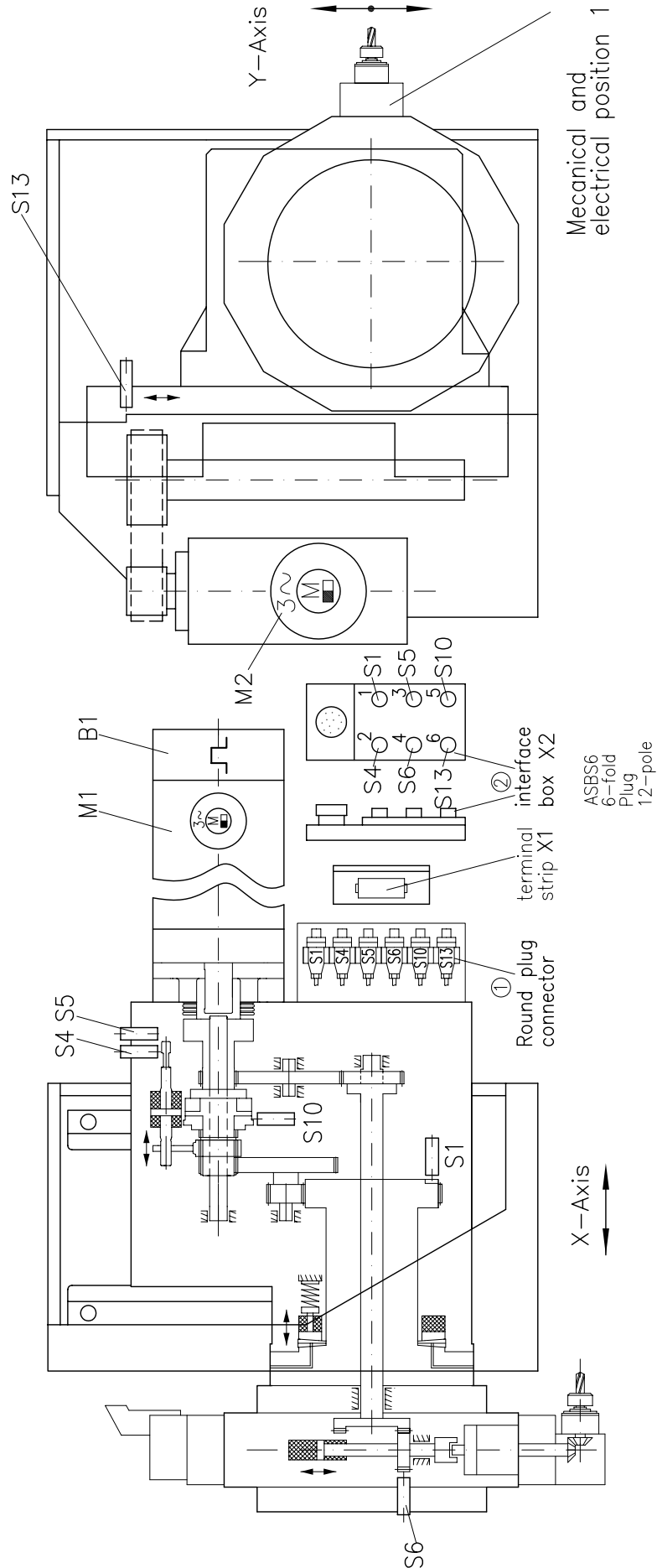



Designation	Element/Function	Line	terminal	Round plug connector Contact No. <sup>①</sup>	coupler plug No.	Quick connect interface box X2 plug 12 contacts pin assignment <sup>②</sup>	Type	Supplier
S1	Proximity switch Reference point tool disk	brown (+)	12	1 (+)	1	11 (+)	BES 516-324-E0-C-01	Balluff
		blue (-)	11	3 (-)		9 gebrückt 10		
		black	1	4		1		
S4	Proximity switch Turret drive "disengaged"	brown (+)	12	1 (+)	2		BES 516-324-E4-C-01	Balluff
		blue (-)	11	3 (-)				
		black	4	4		2		
S5	Proximity switch Turret drive "engaged"	brown (+)	12	1 (+)	3		BES 516-324-E4-C-01	Balluff
		blue (-)	11	3 (-)				
		black	5	4		3		
S6	Proximity switch Tool drive "engaged"	brown (+)	12	1 (+)	4		BES 516-324-E4-C-01	Balluff
		blue (-)	11	3 (-)				
		black	6	4		4		
S10	Proximity switch Ratchetting clutch "engaged"	brown (+)	12	1 (+)	5		BES 516-324-E0-C-01	Balluff
		blue (-)	11	3 (-)				
		black	10	4		5		
S13	Proximity switch Reference point Y-axis	brown (+)	12	1 (+)	6		BES 516-324-E0-C-01	Balluff
		blue (-)	11	3 (-)				
		black	33	4		6		
	Ground					12 (PE)		
B1	Incremental pulse coder						according to order	
M1	Driving motor A.C. Servomotor						according to order	

① Option

② Option

Technical data of:

S1 - S13

Operating voltage:	10-24V DC ±20%
Max. residual ripple:	10%
Max. load current:	200mA
Nom. sensing distance:	1mm
Temperature range:	-20° to +65°C
Function:	n.o. (make) function
Type:	pnp logic



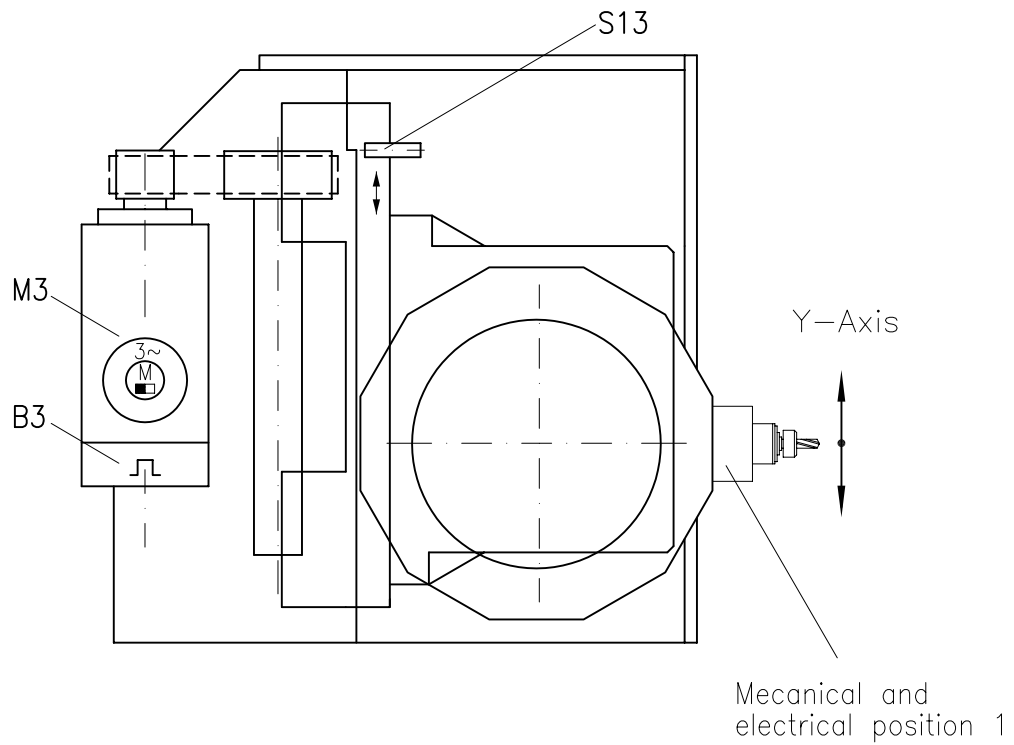
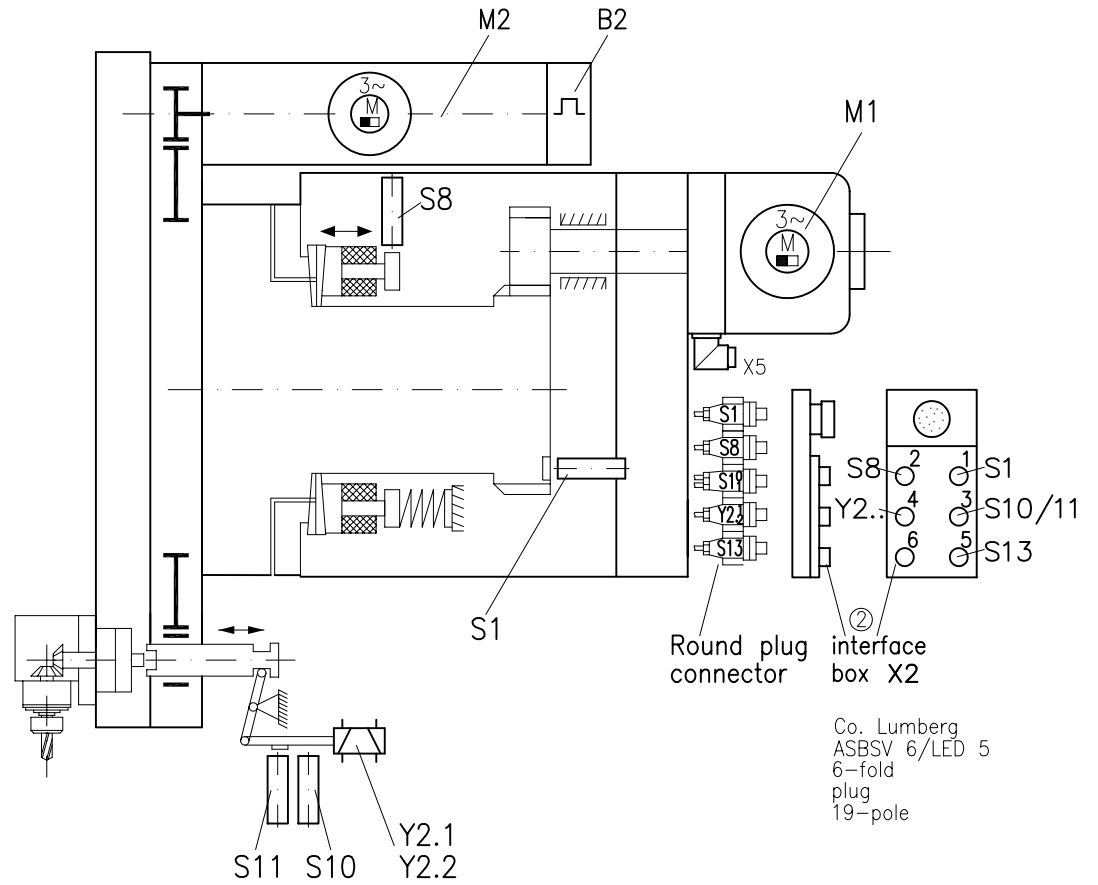



Designation	Element/Function	Line	Round plug connector M12 4pol. Pin Contact No.	Round plug connector M12 5pol. Pin Contact No.	Y-junction Round plug connector M12 4pol. Pin Contact No.	coupler plug No.	Quick connect ② interface box X2 plug 19 contacts pin assignment Co. Lumberg	Motor-Connector X5 GR1 6pol. Pin Contact.-No.	Type	Supplier	
S1	Proximity switch Reference point tool turret	brown (+)	1			1	19 (+)		BES 516-324-E0-C	Balluff	
		blue (-)	3				6 (-)				
		black	4				15				
S8	Proximity switch Tool turret locked	brown (+)	1			2			BES 516-300-S205-D	Balluff	
		blue (-)	3				5				
		black	4								
S10	Proximity switch Tool drive engaged	brown (+)			1	3			BES 516-324-E4-C	Balluff	
		blue (-)			3						
		black			2			8			
S11	Proximity switch Tool drive disengaged	brown (+)			1	3			BES 516-324-E4-C	Balluff	
		blue (-)			3						
		black			4			16			
S13	Proximity switch Reference point Y-axis	brown (+)	1			4			BES 516-324-E0-C	Balluff	
		blue (-)	3								
		black	4					3			
Y2.a	Solenoid engage	2		2		5			GTUW 050 T43 D04 060 24V DC; 21,2W; 0,9A 33,6W; 1,4A	Schultz	
		3		3							
Y2.b	Tool drive disengage	1		3							
		Ground	green-yellow	5				17			
								12 (PE)			
M1	Tool Turret driving motor AC-Servo	black						1	sensorless drive	SAUTER	
		blue						2			
		brown						6			
		Ground	green-yellow					≡			
B2	Tool Drive driving motor AC-Servo								Option		
M2	Encoder system Tool Drive								Option		
B3	Motor Y-axis motor AC-Servo								Option		
M3	Encoder system Motor Y-axis								Option		

① Diode 1N4007 (installed in round plug connector)

② Option

Technical Data of: S1 - S13

Operating voltage: 10-24V DC ±20%  
 Max. residual ripple: 10%  
 Max. load current: 200mA  
 Nom. sensing distance: 1mm  
 Temperature range: -20° to +65°C  
 Function: n.o. (make) function  
 Type: pnp logic





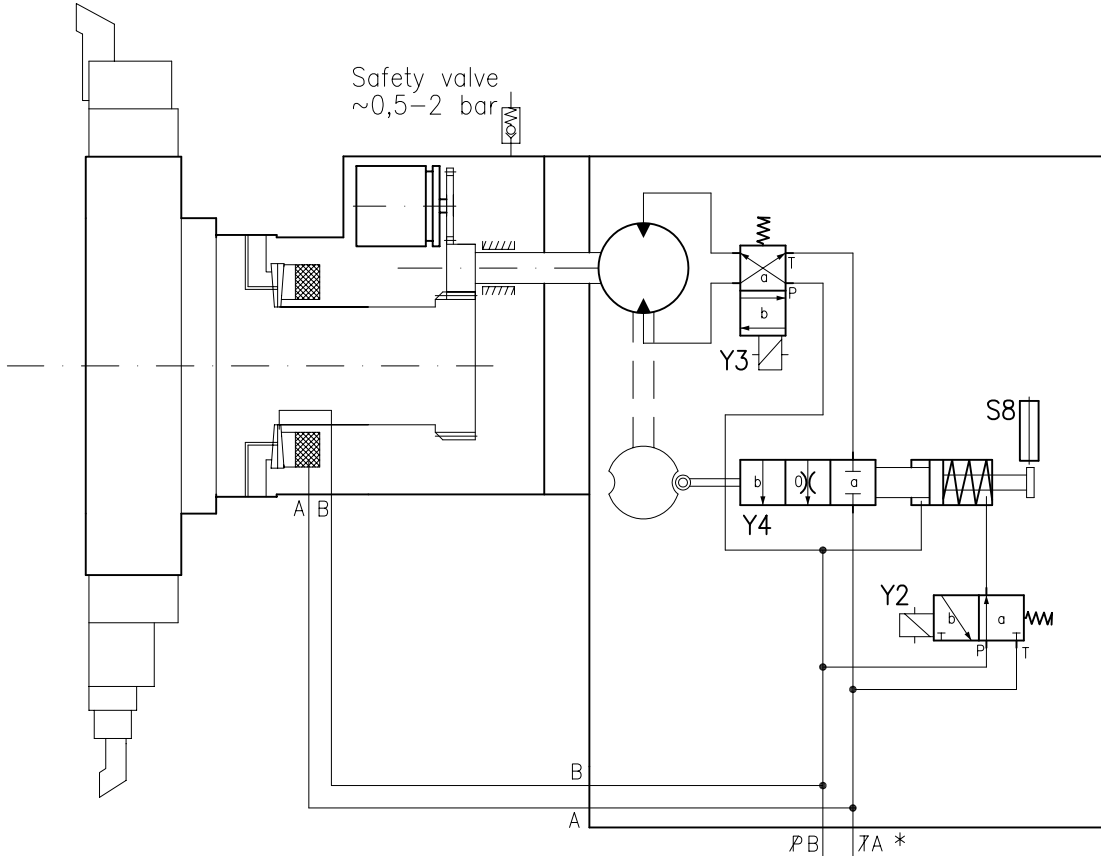

Hydraulics supply

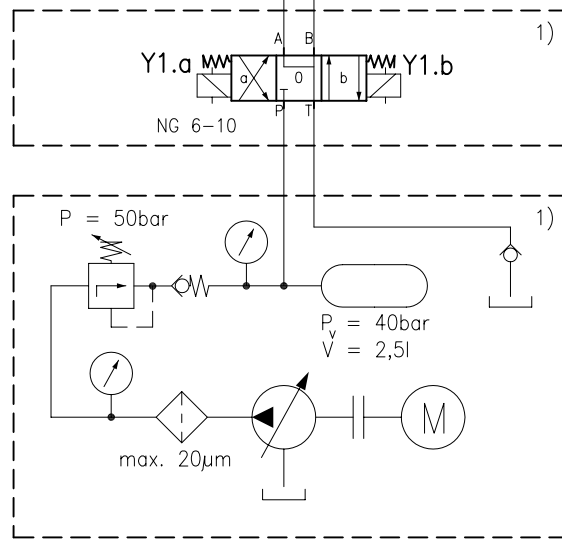

1) Not included in SAUTER delivery volume.

Hydraulic operating pressure:	50 bar ±10%
Oil viscosity:	32-46 mm <sup>2</sup> /s
Recommended operating temperature of the hydraulic oil at the turret:	30-50°C

**!** \* Attention:  
Permissible dynamic pressure  $P_{perm.} \leq 6$  bar  
on turret connection when rotating  
locating disc / tool disc.

X depending on sense of rotation

Length [m]	Turret size					
	.12	.16	.20	.25	.32	.40
≤ 6	10	10	10	12	12	12
> 6	12	12	12	15	15	15
Recommended rated quantity of valve	Rated quantity 6			Rated quantity 10		

Table of functions	Y1		Y2		Y3		Y4	
	a	0	b	a	b	a	0	b
Lock	1	0	0	1	0	1	0	0
Unlock	0	0	1	1	0	X	X	1
Rotate right	*	0	0	1	0	1	0	0
Rotate left	*	0	0	1	0	1	0	0
Position right	0	0	1	1	0	1	0	0
Position left	0	0	1	1	0	0	1	0
Stop	0	1	0	1	0	1	0	0



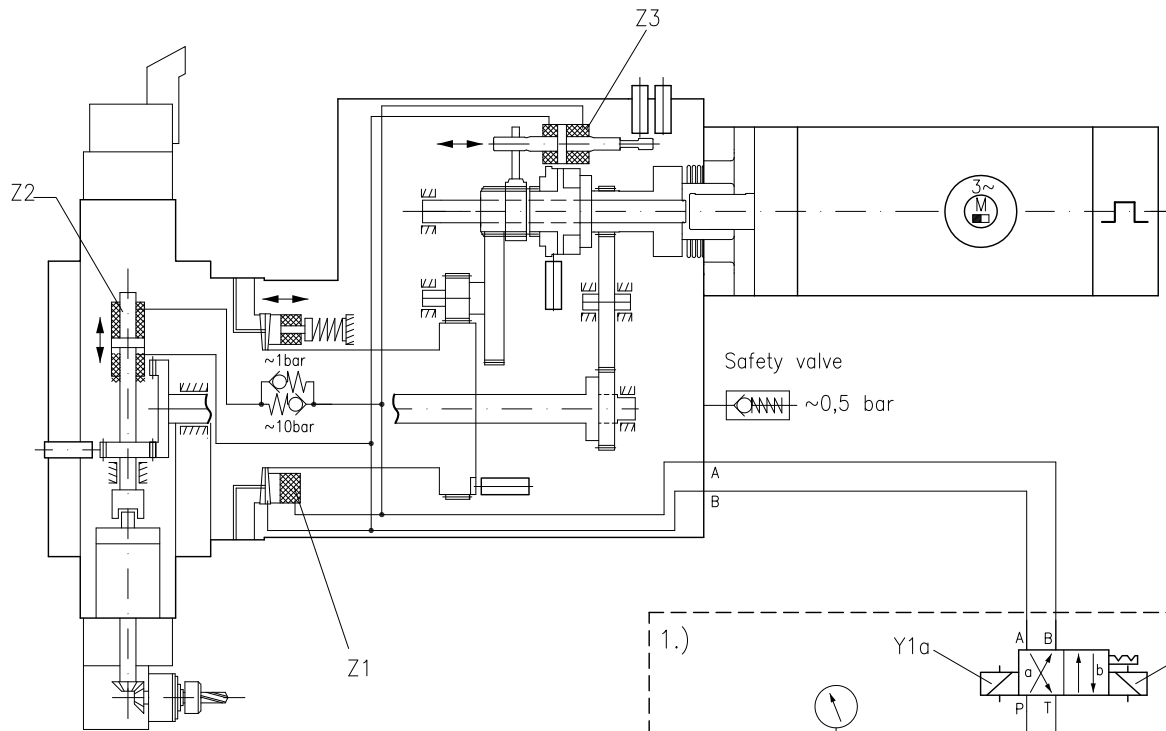

Hydraulics supply  
(example)

Size	V <sub>min</sub> [l]
.12	0,7
.16	0,7
.20	0,7
.25	2,0
.32	2,0

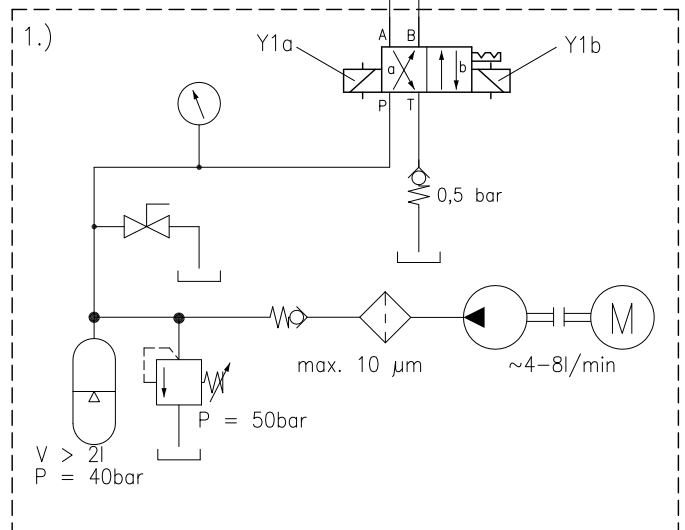

1.) Not included in SAUTER delivery volume.

Air in the hydraulic system endangers the trouble-free operation of the turret. Hydr. supply and pipes to the turret must have options to exhaust.

Table of functions		Y1a	Y1b
Turret	lock	1	0
	unlock	0	1
Turret drive	engage	0	1
	disengage	1	0
Tool drive	engage	1	0
	disengage	0	1

Hydraulic operating pressure	50 bar ±10%
Oil viscosity:	32-46 mm <sup>2</sup> /s
Recommended operating temperature of the hydraulic oil	25-55°C

	Size				
	.12	.16	.20	.25	.32
V	≈ 15	≈ 30	≈ 45	≈ 65	≈ 114
$\dot{V}$	≈ 20 l/min				

Recommended nominal diameter of line between distributing valve and turret:					
Length [m]	Turret Size				
	.12	.16	.20	.25	.32
< 4	6				
4-6	8	8	10	12	12
> 6	10	10	12	15	15
Recommended rated quanti of valve	6	6	6	10	10



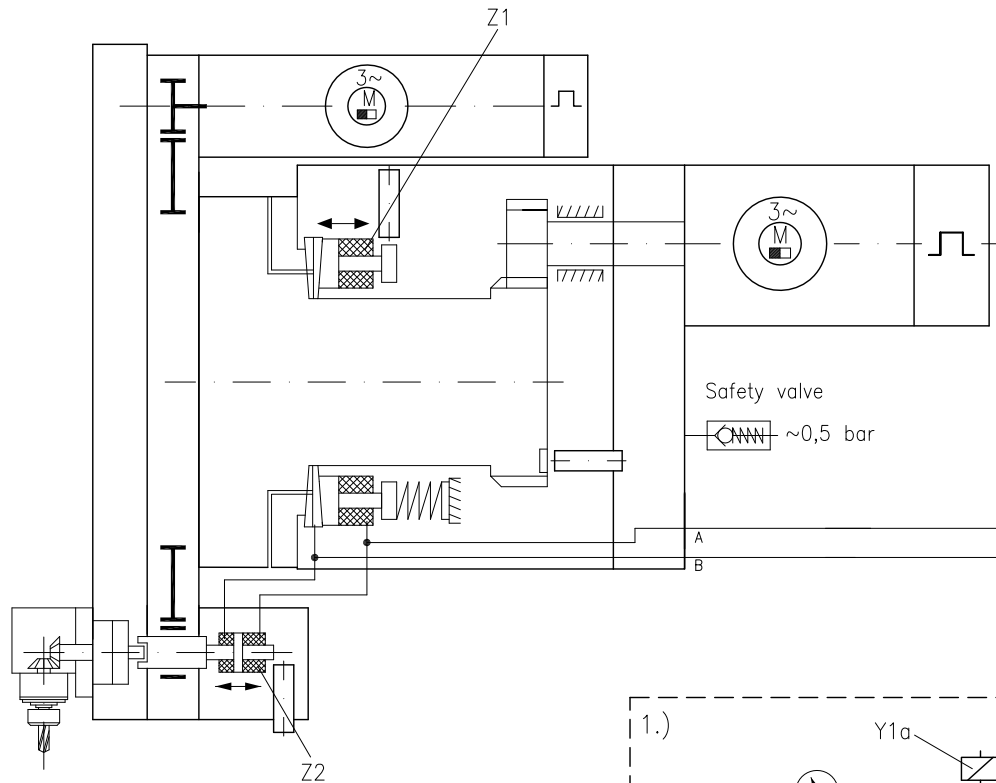

Hydraulics supply  
(example)

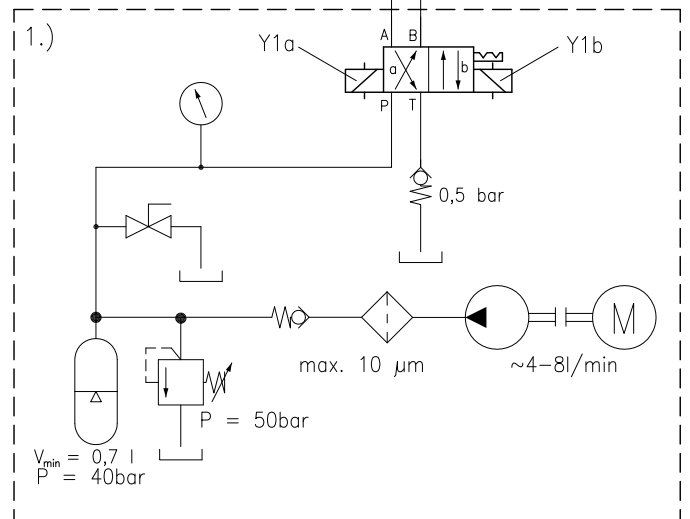

1.) Not included in SAUTER delivery volume.

Table of functions		Y1a	Y1b
Turret	lock	1	0
	unlock	0	1
Tool drive	engage	1	0
	disengage	0	1

Hydraulic operating pressure	50 bar ±10%
Oil viscosity:	32-46 mm <sup>2</sup> /s
Recommended operating temperature of the hydraulic oil	25-55°C

Oil quantity required per indexing cycle [cm <sup>3</sup> ]					
	Size				
	.12	.16	.20	.25	.32
V	≈ 15	≈ 30	≈ 45	≈ 65	≈ 114
$\dot{V}$	≈ 20 l/min				

Recommended nominal diameter of line between distributing valve and turret:					
Length [m]	Turret Size				
	.12	.16	.20	.25	.32
≤ 6	8	8	10	12	12
> 6	10	10	12	15	15
Recommended rated quantity of valve	6	6	6	10	10









Denomination	Designation	Situation	Dimension
01			
02			
03	Tool drive:		
04	Motor	M2 CCW rotation or CW rotation	1 min <sup>-1</sup>
05			1 min <sup>-1</sup> 60
06			0
07			
08			
09			
10	Tool drive clutch		
11	Reversing stroke solenoid	Y 2.1 engage	1
12		Y 2.2 disengage	0
13			
14			
15			
16	Tool drive clutch control:		
18	Proximity switch	S10 engaged	1
19			0
20			
21	Proximity switch	S11 disengaged	1
22			0
23			
24			
25			
26	Enable		
27	Turret	Locked and in set position	1
28			0
29			
30			

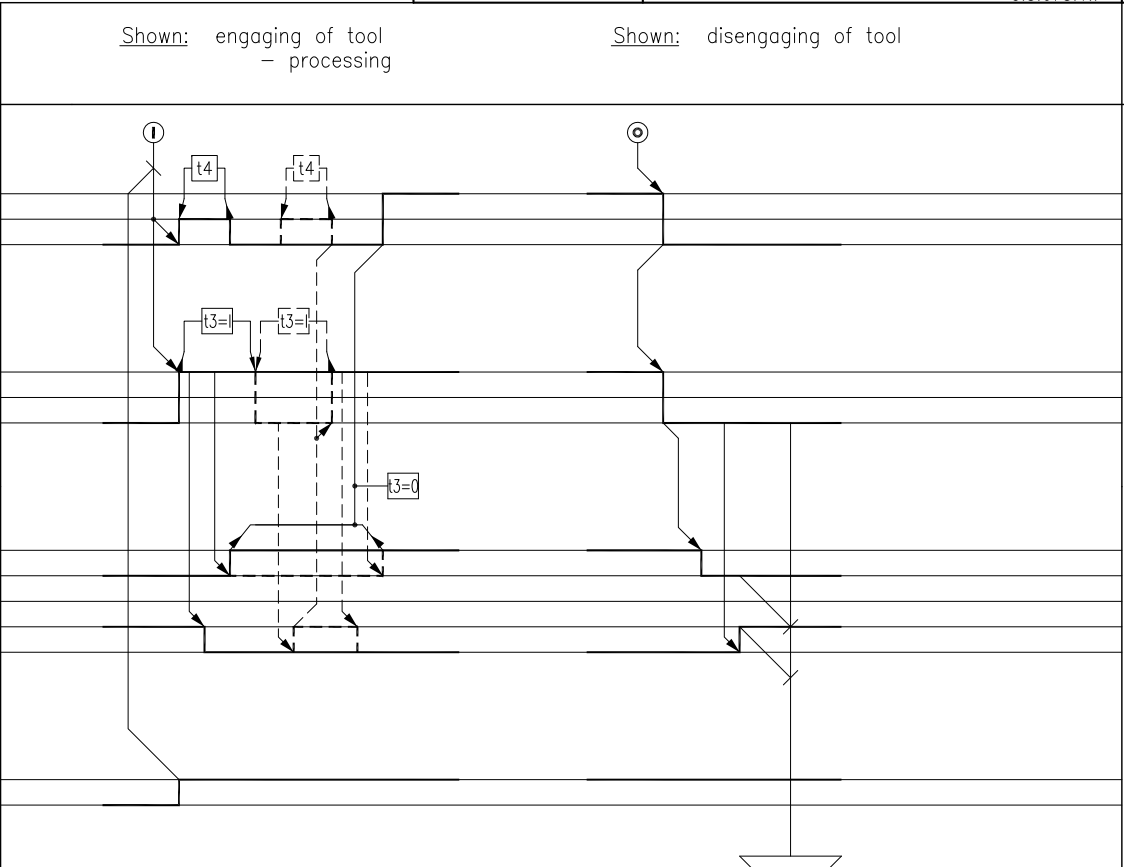

Comments:

Duration:  
t3 = 300ms  
t4 = 200ms

--- Tool drive does not engage:

1. Time t3=300ms reached.
2. Disengage tool drive until proximity detector S11 actuated.
3. Motor on, engage tool drive and restart t3 and t4.

Definition of sens of rotation; seen in direction to motor schaft M2:

For right-hand cutting tools with:

1. Spindle unit, straight: Motor M2 in CCW rot.
2. Spindle unit, angular: Motor M2 in CW rot.

Conditions for tool turret indexing:

1. Solenoid Y<sub>4.2</sub> energized.
2. Proximity-detector S11 actuated.



Diagram of functions

Disk-Type Tool Turret 0.5.6...1..

SK-1307 e  
Z-Doku-IdNr. 090539

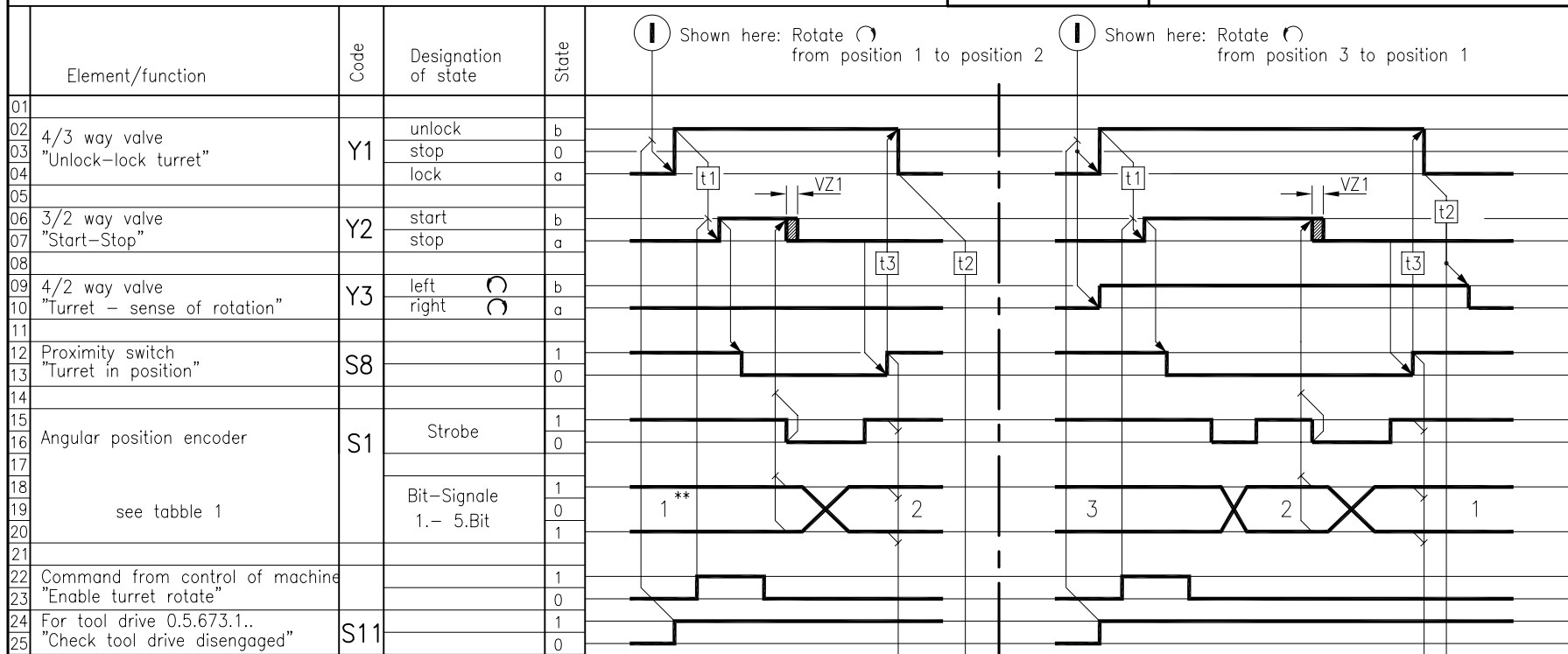

Comments  
Make use of HP-451  
Required delay t1, t2, t3 see table 2  
Max. adm. delay VZ1<sub>max</sub>= 30ms

\* only for 16/24 pos.  
\*\* angular encoder position



Note:  
The turrets of series 0.5.680.1.. with sizes 32 and 40 have 16 resp. 24 indexing positions.  
I. e. a turret with an 8 position tool disc has to be regarded as a 16 position turret.  
I. e. a turret with an 12 position tool disc has to be regarded as a 24 position turret.  
(Information in this regard see product information PI36.3).

Table 1

Angular encoder position	1	2	3	4	5	6	7	8	9	10	11	12	13	14	15	16	17	18	19	20	21	22	23	24
Strobe	1	1	1	1	1	1	1	1	1	1	1	1	1	1	1	1	1	1	1	1	1	1	1	1
1.Bit	1	0	1	0	1	0	1	0	1	0	1	0	1	0	1	0	1	0	1	0	1	0	1	0
2.Bit	0	1	1	0	0	1	1	0	0	1	1	0	0	1	1	0	0	1	1	0	0	1	1	0
3.Bit	0	0	0	1	1	1	1	0	0	0	1	1	1	0	0	0	0	0	0	1	1	1	1	0
4.Bit	0	0	0	0	0	0	0	1	1	1	1	1	1	1	0	0	0	0	0	0	0	0	0	1
5.Bit *	0	0	0	0	0	0	0	0	0	0	0	0	0	0	1	1	1	1	1	1	1	1	1	1
Parity-Check	1	1	0	1	0	0	1	1	0	0	1	0	1	1	0	1	0	0	1	0	1	1	0	0

Table 2

Turret size	t1 (ms)	t2 (ms)	t3 (ms)
12	100	100	-
16	120	120	100
20	170	170	100
25	260	260	100
32	450	450	150
40	450	450	150



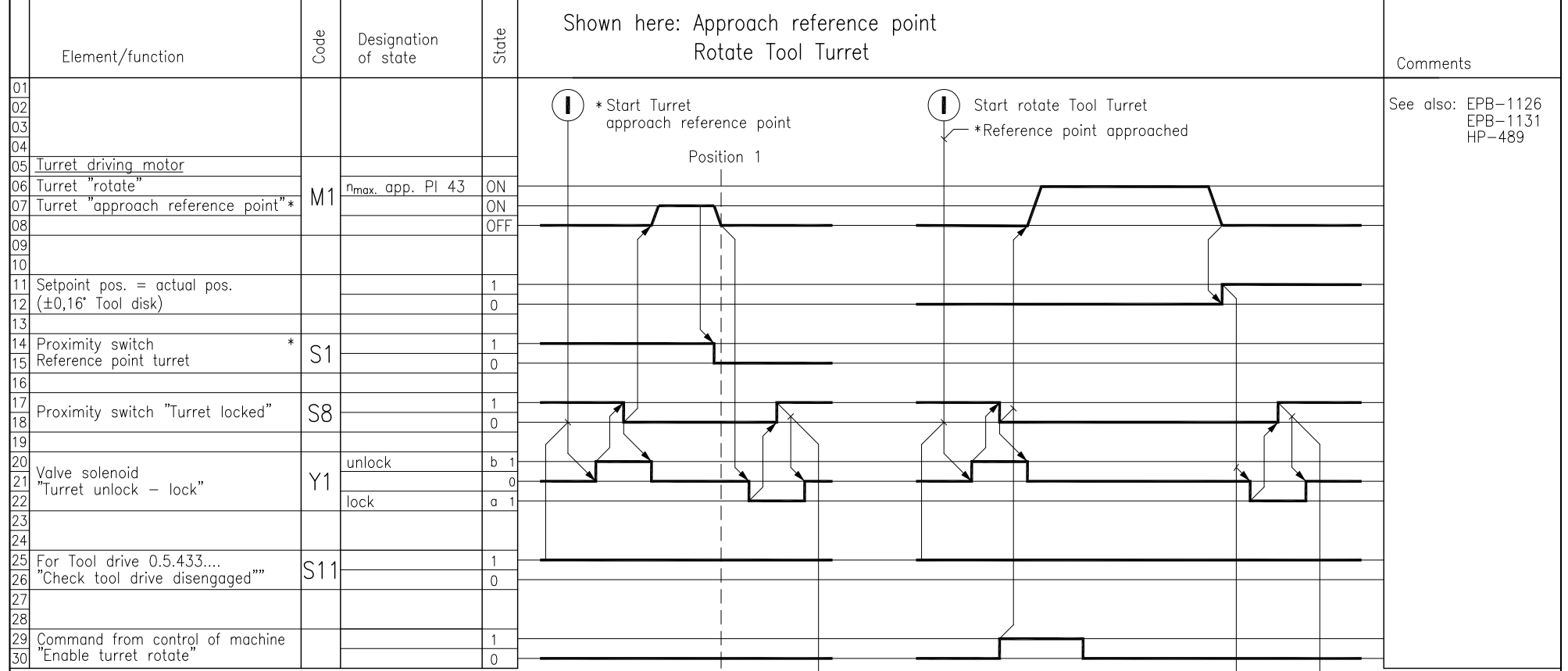

"Approach  
reference point"

Enable  
"Turret in  
position"      Enable  
"Turret  
locked"

\* On turret drive motor with absolute sensor:  
 - S1 not required  
 - Move to reference position cancelled

On turret drive motor with incremental transducer:  
 - S1 required  
 - Move to reference position must be made



Shown here: Approach reference point

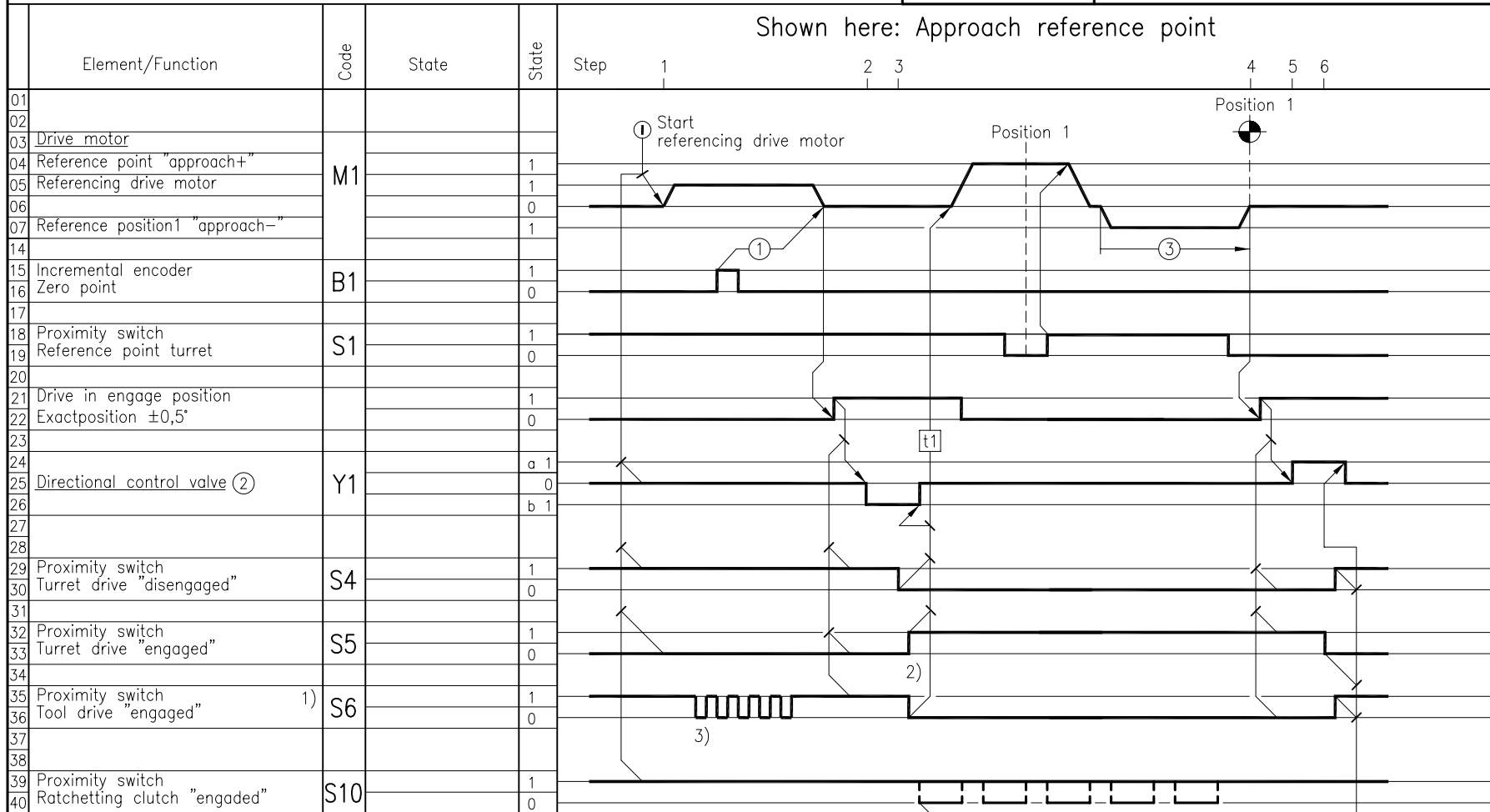

Comments

See also: EPB-1150 HP-496

① Reference point offset

③ Drive to engage position

t1 = 50ms

2) Required supervision  
 Y1.b S5 S6

②

Fault: Hydraulic supply

②

Table of functions		Y1a	Y1b
Turret	lock	1	0
	unlock	0	1
Turret drive	engage	0	1
	disengage	1	0
Tool drive	engage	1	0
	disengage	0	1

**F a u l t**  
 Ratchetting clutch has responded. Motor must be switched of immediately. Having clarified the reason for the fault, the clutch can be reengaged by rotating of the clutch axis. New approach referene point.

"Approach reference point" (Turret in position 1)  
 Enable for  
 -Working with the machine, or  
 -Working with the tool drive.





Shown here: Turret rotate / Tool drive

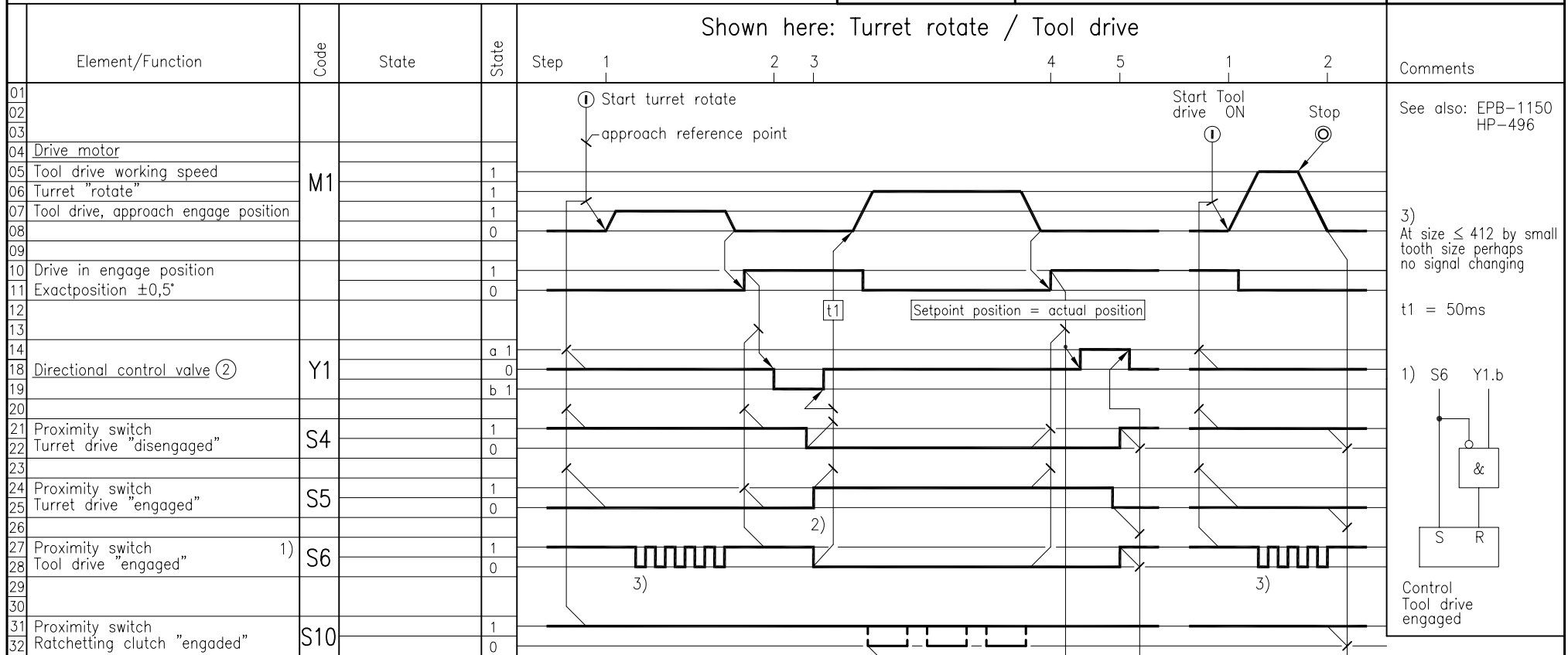

②

Table of functions	Y1a	Y1b
Turret lock	1	0
Turret unlock	0	1
Turret drive engage	0	1
Turret drive disengage	1	0
Tool drive engage	1	0
Tool drive disengage	0	1

F a u l t

Ratchetting clutch has responded. Motor must be switched of immediately. Having clarified the reason for the fault, the clutch can be reengaged by rotating of the clutch axis. New approach referene point.

Enable advance slide to cutting point.

"Turret has been rotated" Enable for -Working with machine, or -Working with tool drive.

Enable for "turret," "rotate"

